

CONTRACT SUMMARY
OPERATORS, HHU

EXPIRATION: May 31, 2010

WAGES: Article XV, Page 18

EFFECTIVE DATE:	6/1/07	6/1/08	6/1/09
Craft Foreman	\$44.75	\$46.00	\$47.30
*Certified Friction Crane Operator Field Mechanics and Field Welders	43.75	45.00	46.30
*Certified Crane Operator requiring an Oiler	42.75	44.00	45.30
*All Other Certified Crane Operators requiring no Oiler	41.75	43.00	44.30
Class 1	40.75	42.00	43.30
Class 2	40.20	41.45	42.75
Class 3	38.15	39.40	40.70
Class 4	36.75	38.00	39.30
Class 5	35.55	36.80	38.10
* City of Chicago Crane License and/or Local 150 Advanced Crane Certification			

FOREMAN: Article VII, Page 10

Foreman is required where 15 or more operators are employed.

FRINGES: Article XV, Page 18

EFFECTIVE DATE:	6/1/07	6/1/08	6/1/09
Health and Welfare	\$8.60	\$9.60	\$10.70
Pension	6.05	6.55	7.05
Vacation	1.90	1.90	1.90
Health/ Welfare Annuity	.50	.75	1.00
Retirement Annuity	.00	.50	1.00
Apprenticeship	.70	1.00	1.15
Industry Advancement Fund and Construction Industry Research and Service Trust Fund	.18	.23	.28
Dues Checkoff	3%	3%	3%

APPRENTICE RATES: Article XV, Page 24

WAGES FOR APPRENTICES

EFFECTIVE DATE:	6/1/07	6/1/08	6/1/09
1st Year	\$21.20	\$21.85	\$22.55
2nd Year	26.50	27.30	28.15
1st Half of 3rd Year	30.55	31.50	32.50
2nd Half of 3rd Year	32.60	33.60	34.65
1st Half of 4th Year	34.65	35.70	36.80
2nd Half of 4th Year	36.70	37.80	39.00

FRINGE BENEFITS FOR FIRST AND SECOND YEAR APPRENTICES

EFFECTIVE DATE:	6/1/07	6/1/08	6/1/09
Health and Welfare	\$8.60	\$9.60	\$10.70
Health and Welfare Annuity	.50	.75	1.00
Pension	4.50	5.00	5.50
Retirement Annuity	.00	.50	1.00
Vacation	1.15	1.15	1.15
Apprenticeship	.70	1.00	1.15
Industry Advancement Fund and Construction Industry Research and Service Trust Fund	.18	.23	.28

FRINGE BENEFITS FOR THIRD AND FOURTH YEAR APPRENTICES

EFFECTIVE DATE:	6/1/07	6/1/08	6/1/09
Health and Welfare	\$8.60	\$9.60	\$10.70
Health and Welfare Annuity	.50	.75	1.00
Pension	6.05	6.55	7.05
Retirement Annuity	.00	.50	1.00
Vacation	1.90	1.90	1.90
Apprenticeship	.70	1.00	1.15
Industry Advancement Fund and Construction Industry Research and Service Trust Fund	.18	.23	.28

OVERTIME: Article III, Page 6

All time in excess of 8 hours per day and/or 40 hours per week and Saturdays shall be paid at the time and one-half rate. Sundays and holidays shall be paid at the double time rate.

SHOWUP: Article III, Page 5

Two hours pay if informed prior to beginning of work. Full day's pay due if started to work or held more than 2 hours. See contract for specifics.

HOLIDAYS: Article III, Page 6

New Year's Day, Decoration Day, Fourth of July, Labor Day, Thanksgiving Day and Christmas Day. A holiday falling on a Sunday shall be celebrated on Monday. If a holiday falls on a day other than a Sunday, it shall be celebrated on that date.

VACATIONS: Article XVI, Page 29

Employer required to add the Vacation contribution to the employee's gross wages and deduct Social Security and Withholding.

SHIFT RATE: Article IV, Page 7

Afternoon shift shall receive \$.75/hr over the regular pay; night shift receives \$.1.00 over the regular rate.

DUES CHECKOFF: Article XVIII, Page 30

Dues Checkoff permitted upon receipt of signed authorization from employee. Amount to be determined by the union. Dues are a deduction from NET PAY.

PREMIUM PAY:

Augers/Drill Rigs - Article VIII, Page 12 - \$.50/hr
Capacity Pay - Article VIII, Page 11 - See Contract
Creter Cranes - Article VIII, Page 12 - \$.50/hr
Electric Submersible Pumps - Article XI, Page 15 - See Contract
Helicopters - Article VIII, Page 12 - See Contract
Long Boom Pay - Article VIII, Page 11 - \$.50/hr
Mechanics Truck - Article VI, Page 9 - \$725/mo
Mining/Boring Machine - Article VIII, Page 12 - \$.50/hr
Small Equipment - Article XI, Page 14 - See Contract
Truck Mounted Concrete Pumps - Article VIII, Page 12 - \$.50/hr
Underground Work - Article VIII, Page 12 - See Contract

**MID-AMERICA REGIONAL
BARGAINING ASSOCIATION**

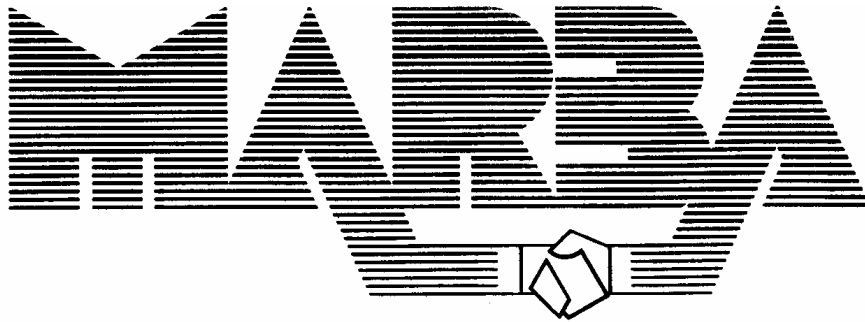

**OPERATING ENGINEERS
HEAVY, HIGHWAY AND UNDERGROUND
AGREEMENT**

BETWEEN

MID-AMERICA REGIONAL BARGAINING ASSOCIATION (MARBA)

AND

**INTERNATIONAL UNION OF OPERATING ENGINEERS
LOCAL 150**

TERM OF AGREEMENT

JUNE 1, 2007 TO MAY 31, 2010

PLEASE NOTE:

A great amount of care has been used in the preparation of this labor contract. However, since MARBA relies on other sources for the information we cannot be responsible for the accuracy or content of the following labor agreement. If you have questions regarding the agreements or if you find errors, please contact the MARBA Office at (847) 699-1283. We will be updating these contracts from time to time and we will advise you of errors as they are brought to our attention.

**OPERATING ENGINEERS LOCAL 150
HEAVY HIGHWAY AND UNDERGROUND
CONSTRUCTION AGREEMENT
Term of Agreement
June 1, 2007 - May 31, 2010**

TABLE OF CONTENTS

	PAGE
JOINT AGREEMENT	1
INTENT	1
PURPOSE	1
 ARTICLE I	
Section 1 Bargaining Unit.....	1
Section 2 New and Unlisted Equipment.....	2
Section 3 Recognition	2
Section 4 Subcontractor.....	2
Section 5 Access to Premises	2
Section 6 No Discrimination	2
Section 7 Scope of Work.....	3
Section 8 Pre-Job/Job Conference	3
Section 9 Prevailing Wage Scale.....	3
Section 10 Successor/Employers.....	3
Notice to the Union	4
No Double-Breasting.....	4
Section 11 Assignment of Work.....	4
 ARTICLE II	
Union Shop	4
Management Rights.....	4
 ARTICLE III	
Section 1 Work Day and Work Week.....	5
Lunch Period.....	5
Call Off	5
Section 2 Holidays	6
Section 3 Overtime.....	6
Section 4 Pay Day.....	6
 ARTICLE IV	
Shift Work.....	7
 ARTICLE V	
Section 1 Severance Pay.....	7
Section 2 Wage Payment.....	7
Section 3 Transportation and Parking.....	8
Section 4 Duties of the Employer.....	8
Section 5 Insurance, Safety, Sanitation	8
Section 6 Cell Phone Prohibition	8
 ARTICLE VI	
Section 1 Maintenance and Heavy Duty Repair	8
Section 2 Loading and Unloading	9
Section 3 Moving.....	9

Section 4	Mechanics	9
ARTICLE VII	Craft Foreman	10
ARTICLE VIII		
Section 1	Preparing Equipment	10
Section 2	Machinery Operation.....	10
Section 3	Machine Reference Guide	11
Section 4	Long Boom Pay.....	11
Section 5	Capacity Pay	11
Section 6	Augers and Drill Rigs	12
Section 7	Creter Cranes.....	12
Section 8	Truck Mounted Concrete Pumps	12
Section 9	Helicopters	12
Section 10	Underground Work.....	12
Section 11	Mining Machines--Boring Machines.....	12
Section 12	Bobcats, Skid Steer Loaders, Forklifts serving Brickmasons & Drills.....	13
Section 13	Tieback Machines	13
Section 14	Asphalt Plants	13
ARTICLE IX		
Section 1	Discharge	13
Section 2	Notice on Leaving Job	13
Section 3	Regular Assigned Engineers	13
Section 4	Changing from One Machine to Another	14
Section 5	Skidsteers	14
Section 6	Idle Time--Class I, Class II, Class III Equipment	14
	Class IV Equipment and Oilers	14
ARTICLE X	Duties of the Oiler	14
ARTICLE XI		
Section 1	Small Equipment.....	15
Section 2	Small Category Equipment Assignment	15
Section 3	Electric Submersible Pumps--Job Sites or Projects	15
Section 4	Electric Submersible Pumps--Tunnels, Etc.	16
ARTICLE XII	Hiring.....	17
ARTICLE XIII		
Section 1	Grievances and Arbitration	17
Section 2	Jurisdictional Award	18
ARTICLE XIV	Job Steward	18
ARTICLE XV	Wage Rates and Fringe Benefits	18
ARTICLE XVI		
Section 1	Welfare Fund.....	25
	Family and Medical Leave Act (FMLA)	26
Section 2	Pension Fund	26
Section 3	Retirement Enhancement Fund	28
Section 4	Vacation Fund	29

ARTICLE XVII	Apprenticeship and Skill Improvement Fund	29
ARTICLE XVIII	Dues Check Off.....	30
	Federal PAC Check-Off	30
ARTICLE XI	Industry Advancement Safety Fund and Construction Industry Research and Service Trust Fund	31
ARTICLE XX		
Section 1	Penalty for Failure to Pay Pension and/or Health and Welfare and/or Vacation Contributions and/or Dues Check Off and/or Joint Grievance Committee or Arbitration Award	32
Section 2	Penalty for Failure to Pay Wages	32
Section 3	Bonding of Employer.....	32
Section 4	Legitimate Picket Line.....	33
ARTICLE XXI	Contract Reopener.....	33
ARTICLE XXII	Savings Clause	33
ARTICLE XXIII	Entire Agreement of the Parties.....	33
MEMORANDA OF AGREEMENT		
	Illustration and Definition of Piggybacking and Staging of Electric Submersible Pumps..	35
	Sewage Treatment Plants	36
	Competition Committee	37
	Work Continuation Program	38
	Mining Machine	39
	Trenching Machines	40
	Wage Payment	41
	Lunch Period - Arbitration Award.....	42
	Crushing Operations.....	43
	Asphalt Plant Operations.....	44
	Concrete Plants	45
	Uniform Drug/Alcohol Abuse Program	46
	Hiring Procedures - Addendum 1	49

**MID-AMERICA REGIONAL BARGAINING ASSOCIATION
HEAVY AND HIGHWAY AND UNDERGROUND CONSTRUCTION AGREEMENT
JOINT AGREEMENT**

THIS AGREEMENT, made and entered into this 1st day of June, 2007, by and between the Mid-America Regional Bargaining Association (MARBA), for and on behalf of the present and future members of its Member Associations, and the individual members thereof, individually and their successors and assigns, hereinafter for convenience, referred to as the "Employer" and the International Union of Operating Engineers, Local Union No. 150, AFL-CIO, hereinafter for convenience, referred to as the "Union".

INTENT

The terms and conditions of this Agreement relating to the employment of employees have been arrived at by means of collective bargaining and the Agreement shall be deemed to be the Agreement of each of the MARBA members and shall be binding on all parties hereto and their respective members. For the purpose of mutual convenience and standardization, this Agreement has been negotiated by and between the Union and the Joint Negotiating Committee of Associations.

PURPOSE

SUBJECT TO THE PROVISION OF THIS AGREEMENT, the purpose of this Agreement is to:

- a) Enter into a definite labor-management contract covering the wages, hours, conditions of work and terms of employment in the relationship between Employer and employee.
- b) Describe the respective rights and responsibilities of the Employer and the Union.
- c) Prevent strikes, lockouts and stoppages of work on account of contract or jurisdictional disputes by requiring prior arbitration procedure.
- d) Promote the efficiency and productivity of the construction industry.
- e) Protect the economic and employment welfare of the employees.
- f) Comply at all times with State and Federal Law governing labor-management relations.
- g) Provide the principle of Union Security.
- h) Preserve to the Employer the basic and intrinsic rights of management to decide and conduct its own operation in a competitive free enterprise system.
- i) Improve the local, state and national economy by quality performance.
- j) Observe and protect the public interest.

ARTICLE I

SECTION 1 - BARGAINING UNIT

The bargaining unit shall consist of all employees engaged in work covered by the occupational jurisdiction of the Union with reference to any and all of the classifications described in Article I, Section 7, "SCOPE OF WORK", and Article XV, Section 1, "Wage Rates and Fringe Benefits," wages, hours of work and all other terms and conditions of employment set forth in this Agreement and the operation, maintenance, repair, moving, dismantling and assembly of all machines used on work coming within the occupational jurisdiction of the Union regardless of motive power, and/or mode of control.

The bargaining unit shall also include, for the purposes of Article XVI, Sections 1 and 2, and for such purposes only, such persons in the employ of an Employer herein referred to as "Supervisors", defined in the LMRA, as amended, as follows:

...have authority, in the interest of an Employer, to hire, transfer, suspend, lay-off, recall, promote, discharge, assign, reward, or discipline, other employees, and who have responsibility to direct them or adjust their grievances, or effectively recommend such action, if in connection with the foregoing, the exercise of such authority is not merely of a routine or clerical nature, but requires the use of judgment, and, provided, further, that such Supervisor:

A. has heretofore been included as a member of the "bargaining unit" as that term is defined in the preceding paragraph of this Article I, Section 1, or as defined in any previous collective bargaining agreement entered into between the parties hereto, and

B. was an employee on whose behalf five (5) years prior to the effective date of this Agreement contributions were required to be made for at least 5,000 hours worked, or wages received, as the case then required.

SECTION 2 - NEW AND UNLISTED EQUIPMENT

It is mutually agreed between the Union and the Association to meet and discuss on wage rates and manning requirements for all new and unlisted equipment which is not listed in this Agreement but that the Union claims under the jurisdiction of International Union of Operating Engineers. Upon written notification of the Association and the contractor by the Union, the parties shall meet to discuss all such matters within twenty-one (21) days from the date of notification. If the parties are unable to resolve such matters, the matter may be submitted within thirty (30) days to a neutral arbitrator. If the Union and the Association and/or Employer cannot agree on an arbitrator, then an arbitrator shall be selected in accordance with the rules and procedures of the American Arbitration Association and the arbitration shall be conducted under and in accordance with such rules and procedures. The cost of such arbitration shall be borne equally by both parties to the arbitration, and the decision of the arbitrator shall be final and binding on all parties and individuals bound by this Agreement. The time limits provided in this Section may be extended by mutual written consent.

SECTION 3 - RECOGNITION

The Associations and the Employers recognize the Union as the sole and exclusive bargaining agent for all employees employed in work covered by the occupational jurisdiction of the Union by Employers who are now members of the Associations and who have assigned their bargaining rights to the Associations, or such Employers as may hereafter become members of the Associations and who assign their bargaining rights to the Associations, or Employers signatory to this Agreement. The Union recognizes the Associations as the sole and exclusive bargaining agent for its members on whose behalf they have bargaining authority and for such other firms, persons or corporations as may hereafter become members of the Association and who assign their bargaining rights to the Associations. The Associations shall keep the Union advised in writing within fourteen (14) days of changes to the list of members who have assigned the Associations their bargaining rights. All other contractor employers engaged in work covered by classifications in this Agreement and the occupational jurisdiction of the Union shall be subject to the terms of this Agreement.

SECTION 4 - SUBCONTRACTOR

The Employer agrees that he will not contract or subcontract any work covered by the Scope of Work of this Agreement and/or work coming under the occupational jurisdiction of the Union to be done at the site of construction, alteration, painting, or repair of a building, structure, or other work, except to a person, firm or corporation, party to the applicable current labor agreement with the Union.

SECTION 5 - ACCESS TO PREMISES

The duly authorized representative of the Union shall be allowed access to any job site or premises. If access is denied, the Union shall request an expedited grievance procedure by fax or other written communication within forty-eight (48) hours with a fine of Ten Thousand Dollars (\$10,000.00) per week. For this purpose it will be the duty of the Employer to provide adequate passes, as requested by the Union, provided the Employer is able to do so.

SECTION 6 - NO DISCRIMINATION

It is understood and agreed that the Employer shall not discriminate against any member of the Union, any of its officers, its stewards, or any member serving as a member of a committee authorized by the Union based upon their Union activity. In the application of provisions of this Agreement, there shall be no discrimination by the Employer or the Union against any individual because of such individual's age, race, color, religion, gender, sexual orientation, disability, or national origin, and when the words in the masculine are used herein it shall include the feminine.

SECTION 7 - SCOPE OF WORK

This Agreement shall apply to work classifications and operations incidental thereto as are herein generally and specifically described:

¹* excavating of all types, paving of all types, bridges, culverts, roads, streets, airport runways, ramps grading, resurfacing, grade separations, overpasses, underpasses, curbs, gutters, sidewalks, parking areas, skyways, caissons, and all other highway construction work, underground and utility work of all types, sewers, subways, tunnels, water mains, piping, pipe jacking, headwalls, outfall structures, junction chambers, concrete construction, conduits, drainage, sheeting, dewatering, pile driving and all other underground utility work, heavy construction work of all types, dams, cofferdams, dock walls, shore protection and all land-based operations involving lakes, harbors, and river improvements; snow removal, flood controls, civil defense, fire and catastrophe operations of all types, landscaping, black dirt and black dirt fields, and wrecking of all types, dismantling or demolition of any building structure, railroad spurs from main line to building line, all farm and land improvements and all assembly and disassembly of all equipment on the job site coming under the jurisdiction of the operating engineers.

In the application of this section, the aforementioned classifications of work and operations shall not be interpreted to include the following:

Construction, erection, modification, addition to or improvement of a building structure or structures, the construction, erection, modification, addition to or improvement of an industrial plant or commercial construction and the driving of sheeting, piling, caisson work, foundation work or dewatering for a building structure, rapid transit stations, pumping station structures above connecting sewer lines, and slurry operations within the outer perimeter of the building line. When a member of the bargaining unit is working within the Scope of this Agreement and is required to work within the scope of another agreement the same day, the conditions and wages in the contract most beneficial to the employee shall prevail.

SECTION 8 - PRE-JOB/JOB CONFERENCE

If the Union or Employer elects, a pre-job/job conference shall be held prior to the commencement of work. At the pre-job/job conference, the Employer shall advise the Union of its requirements as to the workmen required in the respective classifications, the probable starting date, duration of the job, and the machines to be used. The parties shall reduce the Employer's pre-job requirements and agreements to writing, to be signed by an Employer and Union representative

Either party may after a job is in progress, if it deems necessary, request a job conference. The pre-job/job conference must be held within five (5) days from the date of request.

Union has the option to strike if an Employer refuses a written request to attend a pre-job/job conference provided that at least forty-eight (48) hours advance written notice of the Union's intent to strike is given to the Employer.

SECTION 9 - PREVAILING WAGE SCALE

There is set forth in this Agreement in Article XV, a wage scale applicable to work performed by journeymen and apprentices in Cook, DuPage, Will, Kendall, Grundy, Kane, Kankakee, Lake and McHenry counties, all in Illinois, and in Article XV, the applicable wage scales for apprentices in all counties listed above. Such wage scales shall be applicable to contractor, individual, partnership or corporation signatory hereto and their employees engaged in all types of private works and in public works for the state, county, city, United States, or any other public body or any other political or departmental subdivision hereof.

The Union will draft a Rider for an individual Employer to sign when a member works outside of Local 150's geographic scope, and the Rider must be signed by the Employer and the Union.

SECTION 10 - SUCCESSOR/EMPLOYERS

A. SUCCESSOR/EMPLOYERS: This Agreement, when executed by the parties hereto, shall be binding upon the Union and Employer, their successor, heirs, executors, administrators, receivers in bankruptcy, receivers in equity, trustees or any such other equivalent designee.

¹ See letter of clarification regarding sewage disposal plants.

B. NOTICE TO THE UNION: Employer shall give notice to the Union and the appropriate Fund Office in writing immediately after the occurrence of any of the events relating to the Employer, occurring after the date hereof:

1. Sale, assignment, transfer, or other change in name or ownership;
2. Formation of partnerships;
3. Termination of business;
4. Changes of name commonly used in business operation;
5. Change in form of business organization;
6. Incorporation of business;
7. Dissolution of corporation;
8. Name and business organization of successor;
9. Admission to or withdrawal from any association operating as a multi-employer

bargaining agent.

C. NO DOUBLE-BREASTING: In order to protect and preserve work for the employees covered by this Agreement, it is agreed the terms of this Agreement shall apply to any joint venture or separate construction business entity primarily engaged in the construction industry and owned or controlled by the Employer which performs construction work of the type covered by this Agreement within the geographic jurisdiction of this Agreement.

SECTION 11 - ASSIGNMENT OF WORK

A. The Employer hereby agrees to assign ALL work that is to be performed in the categories described in Article I, Section 7, Article VIII, Article XI, and/or Article XV to employees in the bargaining unit covered by this Agreement.

B. The Employer, by entering into this Agreement hereby states and affirms that it is the Employer's preference to have ALL work identified or described in Article I, Section 7, Article VIII, Article XI, and/or Article XV be performed by employees in the bargaining unit represented by the Union covered by this Agreement.

C. Grievances alleging a violation of this Section, based upon assignment of work to employees and/or labor organizations not affiliated with the Building and Construction Trades Department A.F.L.-C.I.O. and/or Joint Conference Board of the Construction Employers' Association and the Chicago & Cook County Building and Construction Trades Council shall be processed through the Grievance Procedure in Article XIII of this Agreement and shall not be considered to be a jurisdictional dispute and thereby excluded from the Grievance Procedure or otherwise subject to a jurisdictional award as that term is defined under Article XIII, Section 2, Jurisdictional Award.

D. The Employer agrees to compensate the bargaining unit member who would have worked but for the Employer's violation of this Section at the double (2x) time rate for all hours the bargaining unit member would have worked but for the Employer's violation.

ARTICLE II

A. UNION SHOP. All employees shall be obligated to become members of the Union after the seventh (7th) day of employment as a condition of continued employment. Any employee who fails to become a member of the Union by his own choice and not by refusal of the Union, or who fails to maintain his Union membership, or non-member who fails to pay required permit fees, shall forfeit his right of employment.

The Union by written notice served by registered mail upon the Employer may demand the discharge of said employee, specifically stating the basis of said demand, and subject at all times to the Union guarantee to defend, save harmless and indemnify the Employer from any claims or damages accruing to the employee as a result of the wrongful discharge demand by the Union. The foregoing in all other aspects shall be subject to existing and applicable Federal and State laws governing labor management relations. This Union security provision shall be subject to immediate negotiation with the Employer as to any further changes permissible under future legal authority.

B. MANAGEMENT RIGHTS. The right to manage and conduct the business, including the right to determine what operations are to be conducted, the methods and means of all operations, to introduce new, improved or changed methods, equipment or facilities, to determine the machinery and equipment to be utilized, the right to hire, promote, manage and direct the work force, to schedule the days,

hours and shifts of operation, to determine when overtime shall be worked, to layoff and recall employees, to curtail or close down any operation, to sell and dispose of all or any part of the Employer's assets, and to contract or subcontract work, except as specifically limited by this Agreement, are reserved solely to the Employer.

ARTICLE III

SECTION 1 - WORK DAY AND WORK WEEK

A. The regular starting time for a single shift operation Sunday through Saturday inclusive shall be scheduled at one of the following hours: 6:00 a.m., 6:30 a.m., 7:00 a.m., 7:30 a.m., or 8:00 a.m.

The Employer must establish a regular starting time, then if the Employer desires to change the established starting time, the employee(s) must be notified before the quitting time of the employee's regular workday of any change in the established starting time for the following day.

B. Eight (8) hours shall constitute a normal workday between the hours of 6:00 a.m. and 2:30 p.m., 6:30 a.m. and 3:00 p.m., 7:00 a.m. and 3:30 p.m., 7:30 a.m. and 4:00 p.m., 8:00 a.m. and 4:30 p.m., as the case may be pursuant to the established starting time as set forth in Section 1(a) of this Article.

The provisions set forth in Section 1a and b of this Article shall not apply if there is a governmental agency requiring a different starting time, in which event such requirement shall be the controlling factor. In no event shall such governmental requirement be interpreted to apply the remainder of this Agreement. For starting times on a single shift operation outside of the normal workday required by a governmental agency, employees shall be paid a premium of Two Dollars (\$2.00) per hour in addition to their straight-time rate of pay in lieu of shift premiums. For any other single shifts where the starting times are outside of the normal workday, there must be a pre-job meeting in which both parties mutually agree to the change.

C. LUNCH PERIOD. There shall be a regularly scheduled lunch period for all one, two and three shift operations. The lunch period shall be one-half (1/2) hour beginning at the midpoint of the shift(s) or 12:00 noon for a single shift operation. The Employer must establish a regular scheduled lunch period at either the midpoint or 12:00 noon and it shall be for a minimum of one (1) week duration beginning on a Monday and the employees must be notified before quitting time of the employees last day of work prior to the Monday of the change in the established lunch period. On a three shift operation, the employees on all three shifts will work seven and one-half (7-1/2) hours and be paid for eight (8) hours with a half (1/2) hour lunch period at the time specified above. On a two shift operation, the employees on both shifts will work seven and one-half (7-1/2) hours and be paid for eight (8) hours with a half (1/2) hour lunch period at the time specified above. On a two shift operation where the employees are working more than eight (8) hours, both shifts shall receive a half (1/2) hour lunch period, and it shall be taken at the midpoint of the shift, for which the employee shall be paid.

If the Employer requires the employee to work during his scheduled lunch period on a multiple shift operation, the employee shall be paid as provided above and in addition shall receive one-half (1/2) hour at the overtime rate for working during his lunch period.

On a single shift operation if the Employer requires the employee to work during his scheduled lunch period, he shall be paid time and one-half (1-1/2) for the lunch period in addition to his normal day's pay.

The above lunch period provision shall also apply to Sundays and holidays, except it shall be paid at the double time (2) rate.

D. CALL OFF. All employees shall be obligated to report for work each day Monday through Friday at the designated starting time as set forth in this Article; however, employees may be notified up until 10:00 p.m. of the previous day for a single shift operation or within six (6) hours after the end of the employee's shift on a multiple shift operation, by an authorized representative of the Employer if there is no work the following day. Otherwise the employee shall report for work and be paid pursuant to the terms of this Article. Employees personally notified on the job before quitting time the previous day or by telephone shall be the only valid means of notification of not reporting for work. The employee shall remain at the job site if so directed by the Employer or his representative. In the event the employee is held more than two (2) hours or is started to work at any time he shall receive a minimum of eight (8) hours pay and shall be paid pursuant to the following for all shifts Sunday through Saturday.

1. An employee who reports to work and is informed prior to the starting time of his regular shift, 6:00 a.m., 6:30 a.m., 7:00 a.m., 7:30 a.m. and 8:00 a.m., respectively, that he will not work that day shall receive two (2) hours pay.

2. An employee who reports for work and is informed prior to preparation time (1/2 hour prior to this established starting time) that he will not work that day and is released before two (2) hours have elapsed beginning with the starting time of his preparation time and has not started to work, shall receive two (2) hours' pay.

3. An employee who reports to work and commences preparing his machine and is informed prior to his regular starting time that he may not work that day and is released before two and one-half (2-1/2) hours have elapsed beginning at the starting time of his preparation time and is not started to work shall receive one-half (1/2) hour at the overtime rate of pay for preparation time and two (2) hours pay for show-up time.

4. An employee who is requested to report for work prior to 6:00 a.m. on a single shift operation or 8:00 a.m., 4:00 p.m., or 12:00 midnight on a two or three shift operation and prior to the requested starting time is informed that he will not work that day shall receive pay at the overtime rate for the hours prior to the starting times listed in this paragraph and two (2) hours pay for show-up time.

5. An employee who is requested to report for work prior to 6:00 a.m. on a single shift operation or 8:00 a.m., 4:00 p.m., or 12:00 midnight on a two or three shift operation and held on the job more than two (2) hours after the regular starting time or has started to work at any time after the requested starting time shall receive pay at the overtime rate for the hours prior to the starting times listed within this paragraph and for eight (8) hour's pay for the normal work day.

6. An employee held on the job more than two (2) hours or is started to work at any time after the employee's regular starting time shall receive a minimum of eight (8) hours pay plus one-half (1/2) hour preparation time when applicable. An employee who is requested to report or who is called out after 8:00 a.m., 4:00 p.m., or 12:00 midnight, respectively, shall be paid back to 8:00 a.m., 4:00 p.m. or 12:00 midnight, respectively, plus one-half (1/2) hour preparation time when applicable, and such hours shall be counted as hours worked in computing overtime.

The above provisions shall be applicable to all single and multiple shifts under the terms of this Agreement. When an employee is requested to report for work on Saturdays, Sundays, or holidays, he shall be paid pursuant to the provisions set forth in this Article, except he shall be paid at the applicable overtime rate of pay.

SECTION 2 - HOLIDAYS

The following holidays are designated as those for which double (2) time shall be paid: NEW YEAR'S DAY, DECORATION DAY, FOURTH OF JULY, LABOR DAY, THANKSGIVING DAY AND CHRISTMAS DAY. A holiday falling on Sunday shall be celebrated on Monday. If a holiday falls on a day other than a Sunday, it shall be celebrated on that date. No work shall be done on Labor Day, except to save life or property.

SECTION 3 - OVERTIME

All time in excess of eight (8) hours per day and/or forty (40) hours per week and before or after the normal workday and Saturdays shall be paid at the time and one-half (1-1/2) rate of pay.

All hours worked on Sundays shall be paid at the double-time (2) rate of pay.

All overtime shall be paid to the next half (1/2) hour.

All hours for which the employee receives wages shall be counted as hours worked in computing overtime.

SECTION 4A - PAYDAY FOR EMPLOYEES DURING THE SHOW-UP TIME PERIOD

Any employee who reports for work on a pay day and is told that there is no work that day shall receive his normal show-up time as long as his paycheck is available to him at his normal place of work during his second hour of his starting time. If an employee is required to wait more than two (2) hours for his paycheck, he shall receive an additional hour's pay for each hour or part of an hour the employee is required to wait for a check unless it has been directly deposited into his account as a result of a Direct Deposit agreement, or previously paid to the employee pursuant to an established payroll service.

SECTION 4B - PAYDAY FOR EMPLOYEES WHO ARE NOT REQUIRED TO WORK DURING CALL OFF

When the Employer notifies the employee(s) that there will be no work and such day is the regular pay day, the employee(s) check shall be made available to him at his regular place of work no later than the end of the second hour from his regular starting time. Where the Employer chooses to pay by check, the

employee(s) shall be compensated two (2) hours at the regular rate of pay for picking up his check plus for each hour or part of an hour beyond the two (2) hour period, he shall receive an additional one (1) hour's pay. If the employee is paid through Direct Deposit on or before his regular payday, he may be called off in accordance with other provisions of the contract and will not be compensated for two hours' time.

ARTICLE IV SHIFT WORK

When shift work is established and work is carried on with three shifts of men working eight (8) hours each, the starting time shall be 8:00 a.m. for the day shift, 4:00 p.m. for the afternoon shift, and 12:00 midnight for the night shift, then only single time shall be paid during weekdays, except as provided in this Article. Rotation of multiple shifts may be established at a job conference.

Employees working on the afternoon shift shall receive an additional Seventy-Five cents (\$0.75) per hour over the regular rate of pay. Employees working on the night shift shall receive an additional One Dollar (\$1.00) per hour over the regular rate of pay.

Where two or three shifts are utilized and the Employer wishes the starting time advanced, a representative of the Union and a representative of the Employer shall meet and agree to the starting time for both shifts.

Where shift work is performed from 12:01 a.m. Saturday to 12:00 midnight Saturday, each shift shall be paid at the rate of time and one-half (1-1/2).

Where shift work is performed from 12:01 a.m. Sunday to 12:00 midnight Sunday, each shift shall be paid at the rate of double (2) time.

All provisions in Article III pertaining to work week, show-up time and workday, preparation time, overtime, holidays, and pay day shall apply to all one, two, and three shift operations.

An employee who has started to work and goes into overtime or works into another shift shall receive overtime until such individual has been released from work (see regular assigned engineer clause).

ARTICLE V

SECTION 1 - SEVERANCE PAY

When the services of an employee are no longer required, he shall receive a full day's pay for the day he is terminated and receive all of his wages before his quitting time, or by Direct Deposit to a previously agreed-upon checking or savings account, or by Certified Mail postmarked within twenty-four (24) hours after his quitting time. If not paid within said twenty-four (24) hours, the Employer shall pay penalty of four (4) hours of pay to such employee at the straight time rate of pay for each succeeding twenty-four (24) hours of delay. It is understood that said twenty-four (24) hour periods shall not include Sundays or holidays. Employees shall not be called at home and terminated.

SECTION 2 - WAGE PAYMENT

Wages shall be payable in United States currency or checks at the option of the Employer, or by Direct Deposit to a previously agreed-upon checking or savings account at the option of the employee, and in no event shall the Employer withhold for more than five (5) days, wages accruing prior to the pay day. At the time of payment of wages, the Employer shall furnish the following information on the check stub or accompanying slip to each employee: regular hours worked and overtime hours worked and all deductions including contributions to the Vacation Fund shall be listed separately.

Payday shall be once each week on a specified day during work hours except when payday falls on a Thursday or Friday and such day or the day after is a holiday the employees must be paid prior to the holiday in question. If an employee is not paid on the regular assigned pay day the Employer shall pay penalty of four (4) hours a day to such employee at the straight time rate of pay for each succeeding twenty-four (24) hours of delay. It is understood that said twenty-four (24) hour periods shall not include Sundays and holidays.

If a payroll check is returned to the employee for insufficient funds, the Employer shall pay a penalty of eight (8) hours at the straight-time rate of pay for the first day of the violation and four (4) hours a day

thereafter until a valid payroll check is received by the employee. It is understood that Sundays and holidays are not included.

SECTION 3 - TRANSPORTATION AND PARKING

Whenever employees of the bargaining unit are employed on a job site or project where they cannot supply their own transportation to the work area to which they are assigned, the Employer shall furnish transportation from the gate or entrance or an adequate parking lot provided for by the Employer to their place of employment. All shifts shall start and end at a specified gate, entrance or parking lot for all employees for whom such transportation is furnished.

SECTION 4 - DUTIES OF THE EMPLOYER

It shall be the duty of the Employer to:

1. Furnish to the employees a sufficient amount of fresh drinking water at the beginning of each shift at the job site and again during the lunch period. Provide an adequate changehouse (for operating engineers) and sanitary toilets at the job site.
2. Provide adequate heated showers for (operating engineers) at the job site on all tunnel jobs.
3. Provide an adequate amount of water to keep the dust down.
4. Maintain proper ventilation in all working areas pursuant to Section 5 of this Article.
5. Provide suitable shelter to protect employees from falling materials and inclement weather; such as hard hats, raingear, summer and/or winter fans and heat housers.
6. Carry Workmen's Compensation insurance in a Company or Association authorized under applicable state laws and regulations to insure the liability to pay compensation under Workmen's Compensation Laws.
7. Make all contributions required under the Illinois Unemployment Compensation Act. When an Employer shall not be subject to the provisions of such Act because of the number of employees in the employing unit, he shall, nevertheless, pursuant to the provisions of said Act, make election to be subject thereto.
8. Pay for specialized training as required by individual owners or government agencies to include all tuition, fees, books and other expenses as well as the wages for time spent in direct training (i.e. HAZMAT or specialized safety training), CDL and recertifications are not included.

Upon forty-eight (48) hours' written notice, the Union shall have the option to strike any Employer who does not comply with numbers 6 and 7 above.

SECTION 5 - INSURANCE, SAFETY, SANITATION

The Employer must make adequate provision to comply with all the rules and laws pertaining to Insurance, Safety and Sanitation as are established by the statutes of the Federal, State and Municipal governments where the work is in progress.

SECTION 6 – CELL PHONE PROHIBITION

The use of cell phones by employees while operating equipment during work hours is prohibited.

ARTICLE VI

SECTION 1 - MAINTENANCE AND HEAVY DUTY REPAIR

When the Employer is performing work covered by this Agreement and such Employer maintains a maintenance and repair shop, or shops, or does repair and equipment maintenance in the field, all employment and applications for employment to perform such work shall be in accordance with the terms and provisions of this Agreement. The Employer shall have the right to have specialized field and shop repair performed by service representatives of manufacturers or equipment dealers who provide such service.

A. Employees shall keep their equipment in good order and good repair at all times, and shall assist in field repair of same. In the event of a breakdown of equipment, the engineer and oiler, if one is assigned to the equipment, can be reassigned while it is being repaired only when members of the bargaining unit are assigned to perform the repair work.

B. If any repair work is to be performed by anyone other than a member of the bargaining unit, the operator and/or oiler shall assist said non-bargaining unit member with the repair, and shall remain with his assigned machine until all repair work is completed.

C. Unassigned machines shall come under the terms and conditions of number 2 above.

D. All lubing or any other servicing of equipment in the field will only be performed by members of the bargaining unit, including all Grease Trucks or other means of servicing equipment. When it has been traditionally and historically assigned by the Employer, lubing and any other servicing of equipment in the shop may be performed by a non-bargaining unit member.

On days when operators and oilers are called off or when repair work goes into overtime on a weekday, Saturday, Sunday or holiday, only a bargaining unit mechanic may perform the repairs with no assistance. If another person is needed to assist, it shall be a member of the bargaining unit.

When warranty work is performed on new equipment, the operator and/or oiler may be reassigned.

The length of time warranty work can be performed by factory service representatives shall be limited to the original factory warranty period.

SECTION 2 - LOADING AND UNLOADING

The loading and unloading of all power driven self-propelled equipment listed in the wage classifications of this Agreement when being moved by means of low-boy trailers, rail, or water on the job site, from job site to job site, yard or shop to job site, etc., shall be deemed the work of the operating engineers and shall be covered by the terms of this Agreement. The Employer may at his discretion assign the employee(s) to act as an escort while such equipment is in transit.

The loading and unloading of unassigned equipment discussed in this section may be done by an employee(s) assigned to another piece of equipment and shall not be considered a violation of Article IX, Section 4. Provided, however, such operation does not violate Article IX, Section 6, the Idle Time provision.

SECTION 3 - MOVING

The moving of all power driven self-propelled equipment listed in the wage classifications of this Agreement when moved under its own power on the job site, from job site to job site, from yard or shop to job site, etc. shall be deemed the work of the operating engineer and shall be covered by the terms of this Agreement. Employees shall receive wages for such travel time until they are returned to the place of origin or their personal transportation, whichever is closer.

If the Employer designates a reporting point other than the job site, employees shall be paid at their applicable rate for time spent going from the reporting point to the job site and if necessary, for returning to the designated reporting point.

SECTION 4 - MECHANICS

Mechanics shall furnish their own tools but shall not be required to furnish special tools such as: Pin Presses, Spanner Wrenches, Air or Electric Wrenches, Gear and Bearing Pullers, Electric Drills, Reamers, Taps and Dies, Oxyacetylene Hoses, Gauges, Torches and Tips, Twenty-Four Inch (24") Pipe Wrenches, over 3/4 Inch Drive Socket Set, Sockets over Two Inches (2"). If by mutual agreement, the mechanic is to use his personal pick-up or similar vehicle for the transporting of his tools, etc., on the job, or from job to job, he shall be compensated at not less than Seven Hundred Twenty-Five Dollars (\$725.00) per month plus all fuels, oil, and any additional insurance rider for said vehicle. In no event shall the furnishing of said vehicle be deemed as a condition of employment. Payment for vehicle rental shall be monthly except in case of a lay-off then it shall be as set forth in Article V, Section 1.

The Employer agrees to pay for or replace with equal quality any tools, (excluding hand tools guaranteed for life by the manufacturer), broken on the job by mechanics or anyone required to furnish their own tools. The Employer shall maintain an insurance policy or assume the cost risk, for loss of the employee's personal tools, or portion thereof, on Company premises, or job site and while in the Company's utility truck, when due to the theft by break-in and entry, including fire and explosions or other circumstances that may happen on the Company premises, or job site, and/or Company's utility truck. The Employer's liability for such loss shall not exceed the actual cost of the tools. It is understood that all employees must furnish the Employer with a complete inventory of the personal tools and their brand. It is further understood that whenever new tools are purchased, the employee must include them on the inventory list previously furnished, and whenever tools are removed, the inventory shall be reduced. If an employee does not supply the Employer with an inventory of tools, responsibility for replacement will not be that of the Employer. All

replacement costs shall be paid within thirty (30) days of a reported loss. Employees must notify the Employer of a loss covered by this provision within three (3) days of knowledge of loss.

ARTICLE VII CRAFT FOREMAN

One bargaining unit employee will be designated the Craft Foreman during any day the Employer employs fifteen (15) or more employees in the bargaining unit, exclusive of supervisory personnel.

The Craft Foreman will be a mechanic, unless the Employer employs no mechanics, in which case the Craft Foreman designation may be assigned to one of the other bargaining unit members employed by the Employer and working as an equipment operator.

The Craft Foreman will be the lead man of the employees in the bargaining unit. Such individual, however, shall neither have the authority to, nor shall he exercise any of the functions customarily exercised by a supervisor within the meaning of the National Labor Relations Act, as amended.

Employees covered by this Agreement do not have authority to exercise independent judgment contrary to established and customary company policy and procedures, and they cannot assign a direct other employees contrary to established and customary company policy and procedures. In no way shall such individual be deemed to be an agent of the Union.

The Craft Foreman will be designated by mutual agreement between the Union and the Employer.

ARTICLE VIII

SECTION 1 - (A) PREPARING EQUIPMENT

Engineers on all cranes up to one (1) cubic yard capacity and engineers operating all derricks and^{2*} all hoists listed in Class I of Article XV hereof, and engineers on cranes of twenty (20) ton lifting capacity or under, shall start one-half (1/2) hour before the regular starting time including shift work to prepare the machine for its operation by oiling, greasing, maintaining and servicing the equipment and shall be paid for said one-half (1/2) hour at the overtime rate.

Combination Backhoe Front Endloader machine with backhoe bucket capacity of less than one (1) cubic yard shall not be subject to preparation time. Combination Backhoe Front Endloader machine with backhoe bucket capacity of one (1) cubic yard or more shall be subject to preparation time.

All Hydraulic Cherry Picker type machines under twelve (12) ton lifting capacity shall not be subject to preparation time.

All Hydraulic Cherry Picker type machines of twelve (12) ton lifting capacity to a gross vehicle weight up to one hundred ten thousand (110,000) pounds shall be subject to preparation time.

All Hydraulic Cherry Picker type machines of over one hundred ten thousand (110,000) pounds gross vehicle weight shall require an engineer and oiler and/or apprentice as the case may be.

All Tieback machines less than sixty thousand (60,000) pounds capacity shall be subject to preparation time.

In the event a dispute arises over the applicability of preparation time, or oiler (Apprentice) requirements, due to the introduction of new models of machines or due to the manufacturer's or employer's de-rating or re-classification of any machine's size, lifting capacity, bucket capacity, or weight, a committee comprised of an equal number of representatives of the Union and the Association signatory hereto shall meet to make an equitable decision of the machine in question. In the event a majority decision cannot be reached, the dispute shall be processed pursuant to the Grievance and Arbitration article of this Agreement.

(B) Engineers on concrete conveyor systems will be present and assist when the conveyor system is being set up or dismantled, operated or moved. The engineer will also maintain the generator running the system. An additional engineer shall be required for each additional generator used and also an additional engineer shall be used if the conveyor system is set up in sections on different levels and is not one continuous set of conveyors.

^{2*} Single drum hoist of motive power less than six horsepower will not require preparation time.

SECTION 2 - MACHINERY OPERATION

All Power Shovels, Cable Backhoes, Cable Draglines, Cable Clamshells and Cranes used in work covered by this Agreement where such machinery is rated by the manufacturer as having a capacity of one (1) cubic yard or over, or over twenty (20) ton lifting capacity, Autograde, ^{3*} Formless Curb and Gutter Machine 36 inches (36") in width and over, Roto Mill Grinder 36 inches (36") in width and over, Slip-Form Paver, Concrete Paver 27E and over, Central Mix Plants, Asphalt Plants, Batch Plants and Trenching machine 30 inches (30") and over, shall require an Engineer and Oiler (Apprentice), regardless of motive power.

All Lattice Boom Cranes originally manufactured after 1990 shall require an Engineer and an Oiler or Apprentice.

All Lattice Boom Cranes originally manufactured prior to 1990 with an original lifting capacity of under 20 tons, shall require an Engineer, but shall not require an Oiler or Apprentice.

All Lattice Boom Cranes twenty (20) tons and under manufactured prior to 1990, the Engineer shall receive one-half (1/2) hour grease time.

If another person is required on any of the above cranes, he shall be a member of the bargaining unit.

Hydraulic machines other than Front Endloaders that are designed to use bucket attachments of various sizes and the manufacturer rates such machines as weighing over one hundred fifteen thousand (115,000) pounds shall require an oiler. Machines that do not require an oiler pursuant to the above shall be subject to preparation time pursuant to Section 1 (A) of this Article, with the exception of Combination Backhoe Front Endloader machine.

In the event machines of a new make, model, design, weight or capacity become available and a dispute arises in regard to the application of the foregoing, a committee comprised of an equal number of representatives of the Union and the Association signatory herein shall meet and based on available information and the manufacturer's specifications issue a majority decision.

In the event a majority decision cannot be reached, the dispute shall be processed pursuant to the Grievance and Arbitration Article of this Agreement.

Non-Lattice Boom Truck Cranes having three (3) axles or less shall not require an oiler. All Non-Lattice Boom Truck Cranes having four (4) axles or more, including dolly (dolly shall count as an axle) shall require an engineer and oiler except as heretofore limited.

On any machine not requiring an oiler when a second man is used, such man shall be an employee of the bargaining unit.

SECTION 3 - MACHINE REFERENCE GUIDE

"Lifting capacity, capacity in cubic yards, manufacturers rating in pounds" and similar references to size, weight, bucket capacity or performance of a machine or piece of equipment shall be determined by reference to Green Guide for Construction Equipment published by Equipment Watch. Such reference guide and the information contained therein with regard to the standard configuration of a specific piece of equipment or machinery shall be utilized, notwithstanding any modifications or alteration to the machine or piece of equipment.

SECTION 4 - LONG BOOM PAY

All engineers operating cranes and derricks of all types with booms of ninety feet (90') to one hundred fifty (150') feet, including jib, shall be compensated an additional Fifty Cents (\$0.50) per hour over and above the regular wage scale for operating such crane. All engineers operating cranes and derricks with booms of more than one hundred fifty (150') feet including jib, shall be compensated the aforementioned Fifty Cents (\$0.50) plus an additional ten cents (\$0.10) per hour over and above the regular wage scale for operating such crane for each additional ten feet (10') of boom or jib.

SECTION 5 - CAPACITY PAY

All engineers operating cranes and derricks with a manufacturers rated maximum capacity exceeding fifty (50) ton shall be compensated Two Cents (\$0.02) per hour for each ton of the rated capacity

^{3*} See letter of intent dated May 6, 1976.

in excess of fifty (50) ton. Long Boom Pay Section 4 and Capacity Pay Section 5 and Premium Pay as provided for in Section 6 of this Article shall not be pyramided, but the highest rate shall prevail.

SECTION 6 - AUGERS AND DRILL RIGS

A. All engineers operating crane mounted earth augers, raised blind hole drills, and truck mounted drill rigs shall be compensated an additional Fifty Cents (\$.50) per hour over and above the regular wage scale for operating such equipment.

B. All engineers operating cranes with pneumatic, hydraulic, or electric driven attachments, earth augers, diesel pile hammers, etc., shall be compensated an additional One Dollar (\$1.00) per hour over and above the regular wage scale for operating such equipment, unless there is an operator already assigned to the attachment. This premium only applies to the crane operator.

SECTION 7 - CRETER CRANES

Concrete conveyors mounted on rough terrain cranes (creter cranes) eighteen (18) ton and over shall require an Engineer and Oiler, less than eighteen (18) ton the Engineer shall receive preparation time. When the creter crane is equipped with a conveyor system capable of extending seventy (70') feet or more, the Engineer shall receive an additional Fifty Cents (\$.50) per hour wage increase over and above the regular rate of pay for operating the creter crane.

SECTION 8 - TRUCK MOUNTED CONCRETE PUMPS AND CONVEYORS

Truck mounted concrete pump or conveyor operations shall require an operator. When such machines are equipped with a boom or conveyor, which is capable of extending ninety feet (90') or more, the engineer shall receive an additional Fifty Cents (\$.50) per hour wage increase over and above the regular rate of pay for operating the concrete pump or conveyor.

SECTION 9 - HELICOPTERS

The use of helicopters (external loads) under the terms of this Agreement shall require a three (3) man crew, one (1) pilot and two (2) controllers. The pilot and controllers must have direct radio communications during the actual hoisting operation.

The crew shall receive the hourly wage rate set forth in this Agreement for crane operators, and in addition, the pilot shall receive long boom pay up to a maximum length of five hundred (500') feet.

SECTION 10 - UNDERGROUND WORK

A. Employees working in tunnels, shafts, etc., shall be paid an additional Forty Cents (\$.40) per hour over the regular negotiated wage rate. In addition to this, employees working under air pressure (1/2 lb. to 7 lbs.) shall receive Fifty Cents (\$.50) per hour over the regular negotiated wage rate. Employees working under air pressure (seven (7) lbs. or over) shall receive Sixty-Five Cents (\$.65) per hour over the regular negotiated wage rate. Underground and air pressure pay differential shall apply for the full shift and all overtime to any employee performing work underground or under air pressure.

B. All shifts shall start and end above ground, or employees engaged in work described in this Section shall be paid an additional one-half (1/2) hour pay as travel pay at the overtime rate from 0 to 10,500 ft., one (1) hour travel pay for over 10,500 ft. to 21,000 ft., one and one-half (1-1/2) hours travel pay for over 21,000 ft. to 31,500 ft. Travel distance shall be measured from point of entry of the employee. Employees must report before their normal starting time as required by the travel time listed herein. At the end of the shift, employees must be out of the shaft at the normal quitting time or be paid overtime pursuant to the terms of this Agreement unless reason for not being out of the shaft is an act or fault of the employee.

SECTION 11 - MINING MACHINES - BORING MACHINES – MICRO-TUNNELING

A. The crew operating and maintaining the mining machines shall be compensated an additional Fifty Cents (\$.50) per hour over and above the regular wage scale for operating and maintaining such machine. For hard rock tunnels twelve (12') feet in diameter and over, the crew shall consist of one (1) operator, one (1) oiler, and one (1) heading mechanic, who shall perform maintenance on any equipment in the tunnel heading. Under twelve (12') feet in diameter, one (1) operator and one (1) oiler. Tunnels other than hard rock under five (5') feet in diameter, one (1) operator, five (5') feet in diameter and over one (1) operator, one (1) oiler.

B. All Micro Tunneling operations shall require three (3) Operators, two (2) Class I Operating Engineers and one (1) Class III Operating Engineer, for tunneling machines and pipe jacking.

SECTION 12 - BOBCATS, SKID STEER LOADERS, FORKLIFTS SERVING BRICK MASONS AND DRILLS

A. The operation of Bobcats and Skid Steer Loaders shall be assigned to Operating Engineers except as otherwise provided herein. Bobcats and Skid Steer Loaders, including those machines equipped with small jackhammers (pencil breakers) may be assigned to Laborers for the following work:

1. building demolition work (inside the structure).
2. minor excavation such as curb tear out, replacement and back filling.
3. raising, lowering or movement of manholes.
4. residential concrete work using one bobcat/skid steer loader. If more than one such machine is used, additional machines shall be assigned to Operating Engineers.

B. Forklifts and bobcats with pallet fork attachments serving eight (8) or more brick masons on commercial projects shall be operated by Operating Engineers. Forklifts and bobcats with pallet attachments serving seven (7) or fewer brick masons on commercial projects may be assigned to Laborers.

C. Drilling operations using air track type machines shall be the jurisdiction of the Laborers. Drills where compressor units do not supply the power in the operation of the drill shall be the jurisdiction of the Operating Engineers. All drills in tunnels are the jurisdiction of the Laborers.

D. The provisions of this Section shall become effective June 1, 1995. Employers who have traditionally assigned any of the above described bobcat and skid steer loader operations to Laborers shall not be required to reassign such work to Operating Engineers but shall assign such work to Operating Engineers as the Laborer employees of the Employer currently assigned to such work leave the employ of the Employer through termination or retirement. Upon request, the Employer shall provide a list of the Laborer employees who are covered by this grandfather provision and shall notify the Operating Engineers when such Laborer employees terminate their employment or retire.

E. Grievances alleging violations of this Section 12 shall be processed through the Grievance Procedure in Article XIII of this Agreement and shall not be considered to be jurisdictional disputes and thereby excluded from the Grievance Procedure.

SECTION 13 - TIEBACK MACHINES

Tieback machines rated by the manufacturer to have working weight of Sixty Thousand (60,000) pounds or more and/or custom built Tieback machines with a working weight of Sixty Thousand (60,000) pounds or more shall require an oiler regardless of motive power.

Tieback machines rated by the manufacturer to have a working weight of less than Sixty Thousand (60,000) pounds and/or custom built Tieback machines with a working weight of less than Sixty Thousand (60,000) pounds shall be subject to the preparation time clause Article VIII, Section 1, of the Agreement regardless of motive power.

SECTION 14 - ASPHALT PLANTS

An Operator and apprentice/oiler shall be present at all times when Plant is in operation. When Plant is not in operation and silo has been loaded the previous day, the operator shall be present to discharge the material from silo.

ARTICLE IX

SECTION 1 - DISCHARGE

The Employer shall have the right to discharge any employee for just cause. The Employer shall notify the Union within twenty-four (24) hours of the discharge of such employee. A written notification to the Union is required in those instances where an Employer does not want a member to be re-dispatched to their company in the future. The member will be unavailable for dispatch to that Employer for a period of two (2) years or sooner at the discretion of the Employer.

SECTION 2 - NOTICE ON LEAVING JOB

No employee shall leave his job without giving due notice to the Employer and the Union.

SECTION 3 - REGULAR ASSIGNED ENGINEERS

The engineers, or crew regularly assigned to a piece of equipment on a single or a multiple shift operation shall be given preference when this piece of equipment is required to work, be repaired or moved (in accordance with Article VI) on a regular workday, Saturday, Sunday and holiday or other overtime.

SECTION 4 - CHANGING FROM ONE MACHINE TO ANOTHER

A. The following shall be the maximum changes an employee shall make during a shift: Machine A to Machine B, back to Machine A plus one other machine. If the rate applicable to one machine is higher than that of another, the higher rate shall apply to and be paid for the full shift. The aforementioned change shall apply to all one, two and three shift operations, respectfully.

B. In interpreting and applying this Article, it is understood and agreed that the language therein is not in any way to be interpreted as a limitation on the amount of work any employee is required to do, but only as a limitation on the number of machines such employee can be required to operate or service.

C. Any employee covered by this Agreement shall not be permitted to change to a machine that another employee covered by this Agreement has been employed to operate unless the latter has been discharged for just cause, and the Union has been notified of such discharge. However, if through no act or fault of the Employer, the Regular Assigned Employee is not available for work, this clause shall be inoperative.

This provision shall not apply to minor machines in the following instances, notwithstanding Article VI, "Regular Engineer":

1. Small compressors, earth rollers and form graders when used on paving work.
2. Small graders, small rollers and small spreaders when used in connection with a blacktop operation.
3. Small combination hoes, trenching machines and post augers used in connection with the installation of traffic signals.

SECTION 5 - SKIDSTEERS - Skidsteers or machines of a like nature that are designed to use bucket attachments of various sizes, such machines shall be in Class V wage category.

SECTION 6 - IDLE TIME - CLASS I, CLASS II, CLASS III EQUIPMENT

In case of a layoff, a machine must be idle two (2) work days before another employee can be assigned to such machine. If such machine is reactivated before the two (2) day period, the original employee shall be given first opportunity of employment on said machine. However, if such employee is not available, this paragraph shall be inoperative.

CLASS IV EQUIPMENT AND OILERS - In case of a layoff, a machine must be left idle one (1) working day before another employee can be assigned to such machine. If such machine is reactivated before the one (1) day period, the original employee shall be given first opportunity of employment on said machine. However, if such employee is not available, this paragraph shall be inoperative.

ARTICLE X DUTIES OF THE OILER

It shall be the duty of the Oiler to keep the machine to which he is assigned thoroughly lubricated and reasonably clean, as instructed by the Engineer and to maintain the machine and assist in such work as directly affects the operation of the machine. The oiler shall be under the technical direction of the Engineer, perform such duties as he prescribes and remain at all times in close proximity to the machine.

The same rules and regulations regarding overtime and working conditions which apply to Engineers shall also apply to oilers, except the oiler shall take his lunch period before or after the engineer and grease the machine during the engineer's lunch time.

ARTICLE XI

SECTION 1 - SMALL EQUIPMENT

An operating engineer servicing and maintaining the following listed Class IV machinery: Small Air Compressors, Small Generators, Small Electric Winches, Welding Machines and Sump Pumps three (3") inch or under shall not be required to maintain more than a total of five (5) such machines of the same type, except Small Electric Winches for which the total number maintained shall not be more than four (4), nor shall such employee be required to service and maintain more than a total of five (5) of the above listed machines in combination. When employees of the bargaining unit are employed to service and maintain mechanical heaters, such employees shall not be required to service and maintain more than a total of five (5) such heaters. Where a member of the bargaining unit is required to service and maintain more than a total of five (5) heaters, such employee shall be compensated at the Class I rate of pay negotiated for Crane Operators in this Agreement. Assignment of such machines shall not exceed a total of eight (8). An Engineer shall not be required on one (1) small heater of less than 250,000 B.T.U.

SECTION 2 - SMALL CATEGORY EQUIPMENT ASSIGNMENT

A. In the event that the Employer uses not to exceed a total of three (3) of the following listed small Class IV equipment in any combination on a job site where members of the bargaining unit are employed by the Employer:

1. Small pumps three (3") inches or under doing intermittent pumping
2. One (1) welding machine
3. Single light plant (50kw and under)
4. Three (3) air-cooled welding machines
5. One (1) similar piece of equipment

A member of the bargaining unit shall be assigned and compensated at the rate of Fifty Cents (\$.50) per hour for the entire shift over and above the negotiated rate.

B. In the event an Employer uses any one of the following (B) 1, (B) 2, (B) 3 on a job site where members of the bargaining unit are employed by the Employer:

1. One (1) air compressor of 250 c.f.m. or under
2. One (1) to eight (8) electric submersible pumps not to exceed three (3") inches each
3. One (1) or two (2) four (4") inch electric submersible pump

A member of the bargaining unit shall be assigned and compensated at the rate of Fifty Cents (\$.50) per hour for the entire shift over and above the negotiated rate.

C. In the event that there are no members of the bargaining unit employed by the Employer on the job site, the Employer shall have the right to operate equipment as listed in any one (only) of the above listed (A) 1, (A) 2, (A) 3, (A) 4, (A) 5, or (B) 1, (B) 2, or (B) 3 until such time as members of the bargaining unit are employed by the Employer on the job site, but in no event is work coming within the jurisdiction of the bargaining unit to be permanently assigned to any other employee.

D. In the event an Employer uses a compressor (1) under 250 c.f.m. on a job site where member(s) of the bargaining unit are employed, a member of the bargaining unit shall be assigned and compensated at the rate of Fifty Cents (\$.50) per hour for the entire shift over and above the members' negotiated rate.

E. In the event an Employer uses a compressor (1) over 250 c.f.m. on a job site where there are no members of the bargaining unit employed sub-section D above shall become inoperative and the Employer shall employ a member of the bargaining unit at the Class IV rate of pay listed in this Agreement.

SECTION 3 - ELECTRIC SUBMERSIBLE PUMPS - JOB SITES OR PROJECTS

A. On a job site where more than eight (8) three inch (3") in diameter or less electric submersible pump are being used, the Employer shall require a full time pump operator at the pump wage rate, to provide for the operation and maintenance of said pumps, during the entire regular daytime shift - Monday through Friday and on such other days as the regular daytime crew are conducting full scale job operations. No other operator shall receive premium pay. In the event of a breakdown in any pumps, the assigned operator shall be subject to call at any time and any day to assist in the installation, servicing or removal and re-location of said pumps. In such breakdown case, the Employer shall notify the Operator by telephone to report to the job site if available for said duty. An employee shall not be required to operate and maintain more than a total of seventy-five inch (75") discharge.

When a discharge exceeds seventy-five inch (75") or when the Combination of A & C does not apply the Employer shall require a second full time pump operator - Monday through Friday on the same basis as stated above. However, the Employer may assign the second pump operator to the second shift. It is further understood when the two (2) aforementioned pump operators are employed the total inches of discharge may be increased to one hundred seventy-five inches (175").

When a discharge exceeds one hundred seventy-five inches (175"), the Employer shall require a third full time pump operator - Monday through Friday on the same basis as stated above. However, the Employer may assign the third pump operator to the third shift.

The conditions set forth herein for the first pump operator is also applied to the second and third pump operators respectively.

B. In the event that the Employer uses electric submersible pumps three inches (3") in diameter or less not to exceed a total of eight (8) such pumps and a member of the bargaining unit is being utilized on the job site, the member shall be assigned to the pumps and shall be compensated at the rate of Fifty Cents (\$.50) per hour for the entire shift over and above the members negotiated rate of pay. An employee shall not be required to operate or maintain more than a total of fifteen inch (15") discharge.

C. In the event the Employer uses one (1) or two (2) four inch (4") electric submersible pumps and a member of the bargaining unit is being utilized on the site, the member shall be assigned to the pumps and shall be compensated at the rate of Fifty Cents (\$.50) per hour for the entire shift over and above the members negotiated rate of pay. An employee shall not be required to operate and maintain more than a total eight inch (8") discharge.

D. In the event the Employer uses more than one (1) or two (2) four inch (4") electric submersible pump or any electric submersible pump larger than four inches (4") in diameter a full time pump operator shall be required Monday through Friday on each shift when pumps are in operation and on such other days as the regular crew is conducting full scale job operations to provide for operation and maintenance of such pump or pumps. An employee shall not be required to operate and maintain more than one hundred fifty inches (150") discharge.

COMBINATION A & C

An employee may be assigned to operate and maintain a combination of A & C pumps above. Such employee shall be compensated at the rate of fifty cents (\$.50) per hour for the entire shift over and above the negotiated pump rate of pay.

COMBINATION D & B

An employee may be assigned to operate and maintain a combination of D & B pumps above. Such employee shall be compensated at the rate of fifty cents (\$.50) per hour for the entire shift over and above the negotiated pump rate of pay.

SECTION 4 - ELECTRIC SUBMERSIBLE PUMPS - TUNNELS, ETC.

The Employer shall require a full time pump operator when B or C of Section 3 above is exceeded and the job or project is minus one hundred (100') feet in depth as per the specifications, bench mark, etc., to operate and maintain electric submersible pumps used on tunnels, shafts, and other underground enclosed work, during the entire daytime shift - Monday through Friday and on such other days as the regular daytime crew are conducting full scale job operations. No other operator shall receive premium pay or be required on the other two shifts in the twenty-four (24) hour day except when the total pump discharge on the project exceeds thirty (30") inches. In this case, a second pump man shall be assigned to the second shift - Monday through Friday and on such other days as the regular second shift crew are conducting full-scale job operations.

In the event the total pump discharge on the project exceeds sixty (60") inches a third pump man shall be assigned to the third shift - Monday through Friday and on such other days as the regular third shift crew are conducting full scale job operations.

When pumps require IN LINE service and maintenance such work will be performed by the normal shift pump operator. When pumps require repair or rebuilding, beyond normal warranty work, such work shall be the work of the mechanics.*⁴

⁴*: See illustration and definition attached to the back of contract.

ARTICLE XII HIRING

When an Employer performs work covered by this Agreement in the areas covered by Local Union No. 150, the following shall apply:

The Employer will obtain all employees used in the performance of such work through the Referral Offices of the Local Union in accordance with the non discriminatory provisions governing the operation of the Local Union's Referral Offices set out in the current effective Addendum No. 1 to this Agreement as if set forth in full herein. Furthermore, subsequent to referral and hire the Employer shall make and maintain all work assignments of preferred employees in full compliance with the provisions of said Addendum No. 1. Employer maintains the right to assignment of preferred employees to other assignments.

ARTICLE XIII

SECTION 1 - GRIEVANCES AND ARBITRATION

For the purpose of this Agreement, the term "grievance" is any claim or dispute involving an interpretation or application of the Agreement by an employee, or an Employer, or the Union, or the Association that one of the other of the aforesaid persons or organizations is violating or has violated this Agreement.

STEP 1. A grievance shall first be taken up between the Union's Business Representative assigned to the job and a designated representative of the Employer. The Union must file the grievance within forty-five (45) days of the date of occurrence giving rise to the grievance or when the affected employee knew or reasonably should have known of the existence of the grievance. Grievances not filed within the forty-five (45) day period are deemed waived and are not subject to being processed through this procedure.

The above forty-five (45) day limit may be waived for violations of Article III, Section 1 - Work Day Work Week, Eight Hour Guarantee, Show Up Pay, Call Off and Prep Time. Also, Article III, Sections 2 and 3. The liability shall be for three (3) years of the violation, verified by audit. Audit fees shall be paid for by the Company, along with a ten percent (10%) penalty payable to the Union.

STEP 2. In the event the grievance cannot be resolved within seven (7) working days of the STEP ONE conference, it shall be reduced to writing and referred for conference and resolution by designated officials of the Union and the Contractor at a pre- grievance hearing to be held at the office of Local 150, 6200 Joliet Road, Countryside, Illinois unless another location is mutually agreed to.

STEP 3. In the event the grievance cannot be resolved by STEP TWO, the written grievance shall be submitted within fifteen (15) days to the Joint Grievance Committee (JGC) created in this Article.

The Union and Association have together created a Joint Grievance Committee to resolve grievances arising under this Agreement. This Committee shall consist of an equal number of members representing Employers and the Union. The Union or Association may appoint alternate members. The Joint Grievance Committee may adopt procedural rules which shall be binding upon all parties to the JGC proceedings.

The Joint Grievance Committee shall have the power to resolve all grievances before it and shall have the right to examine all records of the Employers and employees as is reasonably necessary to resolve the grievance. The Joint Grievance Committee shall have the authority to determine and assess remedies for violations of this Agreement.

Where the Joint Grievance Committee, by majority vote, resolves a grievance, no appeal may be taken and such resolution shall be final and binding on all parties and individuals bound by this Agreement.

If the Joint Grievance Committee is unable to resolve a grievance by majority vote, the grievance may be submitted within thirty (30) days to a neutral arbitrator. If the Union and the Association or the Employer, as the case may be, cannot agree on an arbitrator, then an arbitrator shall be selected in accordance with the rules and procedures of the American Arbitration Association. The cost of such arbitrator shall be borne equally by both parties to the arbitration, and the decision of the arbitrator shall be final and binding on all parties and individuals bound by this Agreement.

The time limits provided in this Section may be extended by mutual written consent of the Union and the Employer or at the discretion of the Joint Grievance Committee.

Neither the Joint Grievance Committee nor an arbitrator shall have any authority to add to, detract from, or in any way alter the provisions of this Agreement or make a new Agreement.

Decisions of the Joint Grievance Committee and Arbitration Awards shall be complied with within seven (7) days of receipt of the decision by the losing party. A party which fails to comply with the seven (7) day period shall be required to pay an additional ten (10%) percent of the amounts as owed as liquidated damages for failure to comply with the decision or award. In the event the prevailing party is required to file suit to enforce the decision or award, and it prevails, it shall be entitled to recover its costs, including attorney's fees, from the losing party.

There shall be no lockout by an Employer during the term of this Agreement.

Except as provided in Article XX, Sections 1 and 2 and 4 of this Agreement, there shall be no strikes or work stoppages by the Union during the term of this Agreement.

SECTION 2 - JURISDICTIONAL AWARD

Unless determined by Jurisdictional Award as hereinafter set forth, all work that has been heretofore performed under agreement or by custom or by area practice with any other local organization shall continue to be so performed until such Jurisdictional Award is made. Whenever a jurisdictional dispute shall arise between local labor organizations, the provisions of this Agreement shall prevail until a Jurisdictional Award has been made by the proper Jurisdictional Board of International Unions of which the local disputing Labor Organizations are members or Labor Board or Project Labor Agreements to which the Union is signatory. The Employer agrees to abide by such Jurisdictional Award, but there shall be no work stoppage while the settlement of the dispute is pending. It is further agreed that the Employer will abide by such mutual agreement reached between the Local Union and other Local Unions and the International Union, including, but not limited to the Plan for the Settlement of Jurisdictional Disputes in the Construction Industry.

ARTICLE XIV JOB STEWARD

The job steward shall be selected by the Union from among the members of the bargaining unit employed at the job site at the time of selection. The job steward shall be a working employee. The Union shall have the right to designate which employee shall be the steward or acting steward. The job steward shall have no special employment priority or security. In case of any minor difficulty, the steward shall be permitted reasonable time to adjust same without pay deduction.

ARTICLE XV

SECTION 1 WAGE RATES AND FRINGE BENEFITS

The wage rates and fringe benefits for the respective classifications set forth below shall be effective on the dates indicated:

FRINGE BENEFITS	6/1/07	6/1/08	6/1/09
HEALTH AND WELFARE	\$ 8.60	\$9.60	\$10.70
HEALTH/WELFARE ANNUITY	.50	.75	1.00
PENSION	6.05	6.55	7.05
RETIREMENT ANNUITY	.00	.50	1.00
VACATION SAVINGS	1.90	1.90	1.90
APPRENTICESHIP	.70	1.00	1.15
INDUSTRY ADVANCEMENT FUND and CONSTRUCTION INDUSTRY RESEARCH AND SERVICE TRUST FUND	.18	.23	.28

WAGES	6/1/07	6/1/08	6/1/09
CRAFT FOREMAN	\$44.75	\$46.00	\$47.30
⁵ * CERTIFIED FRICTION CRANE OPERATOR FIELD MECHANICS and FIELD WELDERS	\$43.75	\$45.00	\$46.30
⁵ * CERTIFIED CRANE OPERATOR REQUIRING AN OILER	\$42.75	\$44.00	\$45.30
⁵ * ALL OTHER CERTIFIED CRANE OPERATORS REQUIRING NO OILER	\$41.75	\$43.00	\$44.30
DOWELL MACHINE WITH AIR COMPRESSOR	\$41.75	\$43.00	\$44.30
CERTIFIED FINISH BLADE CERTIFIED TRACK EXCAVATOR	\$41.75	\$43.00	\$44.30
⁶ + GRADALL and machines of like nature	\$41.75	\$43.00	\$44.30
CLASS I	6/1/07	6/1/08	6/1/09
⁷ * ASPHALT PLANT	\$40.75	\$42.00	\$43.30
ASPHALT HEATER AND PLANER COMBINATION	\$40.75	\$42.00	\$43.30
⁷ * ASPHALT HEATER SCARFIRE	\$40.75	\$42.00	\$43.30
ASPHALT SPREADER	\$40.75	\$42.00	\$43.30
⁷ * AUTOGRADER/GOMACO or other similar type machines	\$40.75	\$42.00	\$43.30
⁷ * ABG PAVER	\$40.75	\$42.00	\$43.30
⁷ * BACKHOES with Caisson attachment	\$40.75	\$42.00	\$43.30
BALLAST REGULATOR	\$40.75	\$42.00	\$43.30
⁷ * BELT LOADER	\$40.75	\$42.00	\$43.30
⁷ * CAISSON RIGS	\$40.75	\$42.00	\$43.30
CAR DUMPER	\$40.75	\$42.00	\$43.30
⁷ * CENTRAL REDI-MIX PLANT	\$40.75	\$42.00	\$43.30
COMBINATION BACKHOE FRONT ENDLOADER MACHINE (1 cu. yd. backhoe bucket or over or with attachments)	\$40.75	\$42.00	\$43.30
⁷ * CONCRETE BREAKER (Truck Mounted)	\$40.75	\$42.00	\$43.30
CONCRETE CONVEYOR	\$40.75	\$42.00	\$43.30
⁷ * CONCRETE PAVER Over 27E cu. ft.	\$40.75	\$42.00	\$43.30
⁷ * CONCRETE PLACER	\$40.75	\$42.00	\$43.30
CONCRETE TUBE FLOAT	\$40.75	\$42.00	\$43.30

⁵* City of Chicago Crane License and/or Local 150 Advanced Crane Certification.

⁶+ Requires Oiler pursuant to Article VIII

⁷* Requires Oiler

CLASS I	6/1/07	6/1/08	6/1/09
⁶⁺ CRANES, ALL ATTACHMENTS (NON CERTIFIED)	\$40.75	\$42.00	\$43.30
^{7*} CRANES, TOWER of all types	\$40.75	\$42.00	\$43.30
CRETER CRANE	\$40.75	\$42.00	\$43.30
CRUSHER, STONE, ETC.	\$40.75	\$42.00	\$43.30
DERRICKS, ALL	\$40.75	\$42.00	\$43.30
DERRICK BOATS	\$40.75	\$42.00	\$43.30
^{7*} DERRICKS, TRAVELING	\$40.75	\$42.00	\$43.30
^{7*} DREDGES	\$40.75	\$42.00	\$43.30
ELEVATORS, OUTSIDE TYPE RACK & PINION AND SIMILAR MACHINES	\$40.75	\$42.00	\$43.30
⁶⁺ FORMLESS CURB AND GUTTER MACHINE	\$40.75	\$42.00	\$43.30
GRADER, ELEVATING	\$40.75	\$42.00	\$43.30
GRADER, MOTOR	\$40.75	\$42.00	\$43.30
GRADER, MOTOR PATROL AUTO PATROL, FOR GRADER, PULL GRADER, SUBGRADER	\$40.75	\$42.00	\$43.30
^{7*} GUARD RAIL POST DRIVER TRUCK MOUNTED	\$40.75	\$42.00	\$43.30
HOISTS, ONE, TWO, & THREE DRUM	\$40.75	\$42.00	\$43.30
⁶⁺ HYDRAULIC BACKHOES	\$40.75	\$42.00	\$43.30
⁶⁺ BACKHOES WITH SHEAR ATTACHMENTS (up to 40' of Boom reach, and an additional Three Cents (\$0.03) per foot thereafter)	\$40.75	\$42.00	\$43.30
LUBRICATION TECHNICIAN	\$40.75	\$42.00	\$43.30
⁹⁺⁺ MANIPULATORS	\$40.75	\$42.00	\$43.30
MUCKING MACHINE	\$40.75	\$42.00	\$43.30
^{7*} PILE DRIVERS AND SKID RIG	\$40.75	\$42.00	\$43.30
PRE-STRESS MACHINE	\$40.75	\$42.00	\$43.30
^{7*} PUMP CRETES DUAL RAM (requires frequent lubrication and water)	\$40.75	\$42.00	\$43.30
^{7*} ROCK DRILL-CRAWLER OR SKID RIG	\$40.75	\$42.00	\$43.30
^{7*} ROCK DRILL TRUCK MOUNTED	\$40.75	\$42.00	\$43.30
ROCK/TRACK TAMPER	\$40.75	\$42.00	\$43.30
^{7*} ROTO MILL GRINDER (36" and over)	\$40.75	\$42.00	\$43.30
ROTO MILL GRINDER (less than 36")	\$40.75	\$42.00	\$43.30
^{7*} SLIP-FORM PAVER	\$40.75	\$42.00	\$43.30
SNOW MELTERS	\$40.75	\$42.00	\$43.30
^{7*} SOIL TEST DRILL RIG TRUCK-MOUNTED	\$40.75	\$42.00	\$43.30
STRADDLE BUGGIES	\$40.75	\$42.00	\$43.30
HYDRAULIC TELESCOPING FORM (tunnel)	\$40.75	\$42.00	\$43.30

CLASS I	6/1/07	6/1/08	6/1/09
⁷ * TRACTOR DRAWN BELT LOADER	\$40.75	\$42.00	\$43.30
TRACTOR DRAWN BELT LOADER with attached pusher (two engineers)	\$40.75	\$42.00	\$43.30
TRACTOR WITH BOOM TRACTAIRE WITH ATTACHMENTS	\$40.75	\$42.00	\$43.30
⁷ * TRAFFIC BARRIER TRANSFER MACHINE	\$40.75	\$42.00	\$43.30
⁶ + TRENCHING TRUCK MOUNTED CONCRETE PUMP with boom	\$40.75	\$42.00	\$43.30
⁸ ** RAISED OR BLIND HOLE DRILLS (tunnel shaft)	\$40.75	\$42.00	\$43.30
⁷ * UNDERGROUND BORING and/or MINING MACHINES 5 ft. in diameter and over tunnel, etc.	\$40.75	\$42.00	\$43.30
UNDERGROUND BORING and/or MINING MACHINES under 5 ft.	\$40.75	\$42.00	\$43.30
⁷ * WHEEL EXCAVATOR WIDENER (Apsco)	\$40.75	\$42.00	\$43.30
CLASS II	6/1/07	6/1/08	6/1/09
⁷ * BATCH PLANT	\$40.20	\$41.45	\$42.75
BITUMINOUS MIXER	\$40.20	\$41.45	\$42.75
BOILER AND THROTTLE VALVE	\$40.20	\$41.45	\$42.75
BULLDOZERS	\$40.20	\$41.45	\$42.75
CAR LOADER TRAILING CONVEYORS	\$40.20	\$41.45	\$42.75
COMBINATION BACKHOE FRONT ENDLOADER MACHINE (less than 1 cu. yd. backhoe bucket or over with attachments)	\$40.20	\$41.45	\$42.75
COMPRESSOR AND THROTTLE VALVE	\$40.20	\$41.45	\$42.75
COMPRESSOR, Common Receiver (3)	\$40.20	\$41.45	\$42.75
CONCRETE BREAKER OR HYDRO-HAMMER	\$40.20	\$41.45	\$42.75
CONCRETE GRINDING MACHINE	\$40.20	\$41.45	\$42.75
CONCRETE MIXER OR PAVER 7S series to and including 27 cu.ft.	\$40.20	\$41.45	\$42.75
CONCRETE SPREADER	\$40.20	\$41.45	\$42.75
CONCRETE CURING MACHINE Burlap machine, Belting machine and Sealing machine	\$40.20	\$41.45	\$42.75
CONCRETE WHEEL SAW	\$40.20	\$41.45	\$42.75

⁸ ** To be manned pursuant to the letter dated May 2, 1977

CLASS II	6/1/07	6/1/08	6/1/09
CONVEYOR MUCK CARS (Haglund or similar type)	\$40.20	\$41.45	\$42.75
DRILLS, (all)	\$40.20	\$41.45	\$42.75
FINISHING MACHINE –Concrete	\$40.20	\$41.45	\$42.75
HIGHLIFT SHOVELS or FRONT ENDLOADER	\$40.20	\$41.45	\$42.75
HOIST-SEWER DRAGGING MACHINE	\$40.20	\$41.45	\$42.75
HYDRAULIC BOOM TRUCKS (all attachments)	\$40.20	\$41.45	\$42.75
HYDRO-BLASTER (requires two operators)	\$40.20	\$41.45	\$42.75
⁹⁺⁺ LASER SCREED	\$40.20	\$41.45	\$42.75
ALL LOCOMOTIVES, DINKY	\$40.20	\$41.45	\$42.75
⁹⁺⁺ OFF-ROAD HAULING UNITS (including articulating)	\$40.20	\$41.45	\$42.75
⁹⁺⁺ NON SELF-LOADING EJECTION DUMP	\$40.20	\$41.45	\$42.75
PUMP CRETES: Squeeze cretes - screw type pumps, Gypsum Bulker and pump	\$40.20	\$41.45	\$42.75
ROLLER, ASPHALT	\$40.20	\$41.45	\$42.75
ROTARY SNOW PLOWS	\$40.20	\$41.45	\$42.75
ROTOTILLER, SEAMAN, etc. Self-propelled	\$40.20	\$41.45	\$42.75
SCOOPS (TRACTOR DRAWN)	\$40.20	\$41.45	\$42.75
SELF-PROPELLED COMPACTOR	\$40.20	\$41.45	\$42.75
SPREADER (CHIP-STONE, etc.)	\$40.20	\$41.45	\$42.75
SCRAPER	\$40.20	\$41.45	\$42.75
SCRAPER - prime mover in tandem (regardless of size) (Add \$1.00 to Class II hourly rate for each hour and for each machine attached thereto, add \$1.00 to Class II hourly rate for each hour)	\$40.20	\$41.45	\$42.75
TANK CAR HEATER	\$40.20	\$41.45	\$42.75
TRACTORS, PUSHING, PULLING Sheeps foot, Disc, Compactor, etc. (When pulling a Powder Site Spreader shall be \$1.00 over scale)	\$40.20	\$41.45	\$42.75
TUG BOATS	\$40.20	\$41.45	\$42.75
MECHANIC-WELDERS working in a permanent shop. Such mechanics when working as field mechanics shall receive the Field Mechanics rate of pay for the entire day.	\$40.20	\$41.45	\$42.75

This clause shall not apply to work performed within the construction area.

^{9 ++} These wage classifications become effective June 1, 2007, and apply only where Employers have determined to assign the operation of such machinery to employees represented by Local 150.

<u>CLASS III</u>	6/1/07	6/1/08	6/1/09
BOILERS	\$38.15	\$39.40	\$40.70
BROOMS, ALL POWER PROPELLED	\$38.15	\$39.40	\$40.70
CEMENT SUPPLY TENDER	\$38.15	\$39.40	\$40.70
COMPRESSOR, Common Receiver (2)	\$38.15	\$39.40	\$40.70
CONCRETE MIXER (Two bag and over)	\$38.15	\$39.40	\$40.70
CONVEYOR, PORTABLE	\$38.15	\$39.40	\$40.70
FARM-TYPE TRACTORS Used for mowing, seeding, etc.	\$38.15	\$39.40	\$40.70
FIREMAN ON BOILERS	\$38.15	\$39.40	\$40.70
FORKLIFT TRUCKS	\$38.15	\$39.40	\$40.70
GROUTING MACHINE	\$38.15	\$39.40	\$40.70
HOISTS, AUTOMATIC	\$38.15	\$39.40	\$40.70
HOISTS, ALL ELEVATORS	\$38.15	\$39.40	\$40.70
HOISTS, TUGGER SINGLE DRUM	\$38.15	\$39.40	\$40.70
JEEP DIGGERS	\$38.15	\$39.40	\$40.70
⁹⁺⁺ LOW BOYS	\$38.15	\$39.40	\$40.70
PIPE JACKING MACHINES	\$38.15	\$39.40	\$40.70
POST-HOLE DIGGER	\$38.15	\$39.40	\$40.70
POWER SAW, CONCRETE Power Driven	\$38.15	\$39.40	\$40.70
PUG MILLS	\$38.15	\$39.40	\$40.70
ROLLERS, other than asphalt	\$38.15	\$39.40	\$40.70
SEED AND STRAW BLOWER	\$38.15	\$39.40	\$40.70
STEAM GENERATORS	\$38.15	\$39.40	\$40.70
STUMP MACHINE	\$38.15	\$39.40	\$40.70
WINCH TRUCK with "A" Frame	\$38.15	\$39.40	\$40.70
WORK BOATS	\$38.15	\$39.40	\$40.70
TAMPER-form-motor driven	\$38.15	\$39.40	\$40.70
 <u>CLASS IV</u>	 6/1/07	 6/1/08	 6/1/09
AIR COMPRESSOR – small 250 and under (1 to 5 not to exceed a total of 300 ft.)	\$36.75	\$38.00	\$39.30
AIR COMPRESSOR - large over 250	\$36.75	\$38.00	\$39.30
COMBINATION - Small Equipment Operator	\$36.75	\$38.00	\$39.30
DIRECTIONAL BORING MACHINE	\$36.75	\$38.00	\$39.30
GENERATORS - Small 50 kw and under	\$36.75	\$38.00	\$39.30
GENERATORS - Large over 50 kw	\$36.75	\$38.00	\$39.30
HEATERS, Mechanical	\$36.75	\$38.00	\$39.30
HYDRAULIC POWER UNIT (pile driving, extracting, or drilling)	\$36.75	\$38.00	\$39.30
HYDRO-BLASTER (requires two operators)	\$36.75	\$38.00	\$39.30
LIGHT PLANTS, all (1 through 5)	\$36.75	\$38.00	\$39.30

CLASS IV	6/1/07	6/1/08	6/1/09
PUMPS, over 3" (1 to 3, not to exceed a total of 300 ft.)	\$36.75	\$38.00	\$39.30
PUMPS, WELL POINTS	\$36.75	\$38.00	\$39.30
TRACTAIRE	\$36.75	\$38.00	\$39.30
WELDING MACHINES (2 through 5)	\$36.75	\$38.00	\$39.30
WINCHES, 4 small electric drill winches	\$36.75	\$38.00	\$39.30

CLASS V	6/1/07	6/1/08	6/1/09
SKIDSTEER LOADER (all)	\$35.55	\$36.80	\$38.10
BRICK FORKLIFTS	\$35.55	\$36.80	\$38.10
OILERS	\$35.55	\$36.80	\$38.10
⁹⁺⁺ DIRECTIONAL BORING MACHINE LOCATOR	\$35.55	\$36.80	\$38.10

WINTER MAINTENANCE WORK	6/1/07	6/1/08	6/1/09
MAINTENANCE work done in shop or yard, excluding Master Regular Mechanics, during period from December 1 to March 31	\$36.30	\$37.55	\$38.85

HAZMAT PAY

Level A	Add \$3.00 to Classification
Level B	Add \$2.00 to Classification
Level C	Add \$1.00 to Classification

SECTION 2

FRINGE BENEFITS FOR FIRST AND SECOND YEAR APPRENTICES

	6/1/07	6/1/08	6/1/09
HEALTH AND WELFARE	\$8.60	\$9.60	\$10.70
HEALTH/WELFARE ANNUITY	.50	.75	1.00
PENSION	4.50	5.00	5.50
RETIREMENT ANNUITY	.00	.50	1.00
VACATION	1.15	1.15	1.15
APPRENTICESHIP	.70	1.00	1.15
INDUSTRY ADVANCEMENT FUND AND CONSTRUCTION INDUSTRY RESEARCH AND SERVICE TRUST FUND	.18	.23	.28

FRINGE BENEFITS FOR THIRD AND FOURTH YEAR APPRENTICES

	6/1/07	6/1/08	6/1/09
HEALTH AND WELFARE	\$8.60	\$9.60	\$10.70
HEALTH/WELFARE ANNUITY	.50	.75	1.00
PENSION	6.05	6.55	7.05
RETIREMENT ANNUITY	.00	.50	1.00
VACATION	1.90	1.90	1.90
APPRENTICESHIP	.70	1.00	1.15
INDUSTRY ADVANCEMENT FUND AND CONSTRUCTION INDUSTRY RESEARCH AND SERVICE TRUST FUND	.18	.23	.28

WAGES FOR APPRENTICES

	6/1/07	6/1/08	6/1/09
First Year	\$21.20	\$21.85	\$22.55
Second Year	26.50	27.30	28.15
First half of Third Year	30.55	31.50	32.50
Second half of Third Year	32.60	33.60	34.65
First half of Fourth Year	34.65	35.70	36.80
Second half of Fourth Year	36.70	37.80	39.00

At the end of the fourth year, apprentices shall become Journeymen Engineers and shall be paid pursuant to the terms of the wage classifications set forth in this Agreement.

In no event shall the rate of pay for apprentices exceed that rate provided for the classification of machine the apprentice may be operating as contained in Article XV of this Agreement.

Apprentices shall be paid according to the Apprenticeship Introduction Slip issued to the Employer and the Apprentice at the time the apprentice is dispatched by the Union to the Employer.

The Introduction Slip must indicate the progress status of the apprentice. As the apprentice progresses in status, he shall be paid pursuant to the rates set forth in this Agreement.

In addition to the above provisions for rates of pay, fringe benefit contributions shall be as provided for in this Agreement covering work being performed by said apprentices.

ESTABLISHMENT OF JOINT LABOR MANAGEMENT COMMITTEE FOR CERTIFICATION/TRAINING/TESTING DATA BASE

The Parties agree to establish a Labor Management Committee to develop and implement a program whereby Operating Engineers will be certified as being competent to operate most of the types of equipment covered by this Agreement. The Labor Management Committee created under this provision shall establish the standards and criteria for certification of competency. The Labor Management Committee will have the authority to add new equipment to the certified Operator list, when mutually agreed to. The premium pay for all additional certified classifications will be One Dollar (\$1.00) per hour over the regular hourly rate.

A website will be developed and implemented to validate testing and training of the bargaining unit members.

ARTICLE XVI

SECTION 1 - WELFARE FUND

Effective June 1, 2007, the Employer shall pay Eight Dollars and Sixty Cents (\$8.60) per hour for each hour for which the employee receives wages under the terms of this Agreement into the Midwest Operating Engineers Welfare Fund.

Effective June 1, 2007, the Employer shall pay Eight Dollars and Sixty Cents (\$8.60) per hour for each hour worked by a Supervisor covered by this Agreement into the Midwest Operating Engineers Fund.

Effective June 1, 2007, the Employer shall pay an additional Fifty Cents (\$0.50) per hour for each hour for which the employee receives wages under the terms of this Agreement into the Midwest Operating Engineers Welfare Fund's Retiree Medical Savings Plan.

Effective June 1, 2008, the Employer shall pay Nine Dollars and Sixty Cents (\$9.60) per hour for each hour for which the employee receives wages under the terms of this Agreement into the Midwest Operating Engineers Welfare Fund.

Effective June 1, 2008, the Employer shall pay Nine Dollars and Sixty Cents (\$9.60) per hour for each hour worked by a Supervisor covered by this Agreement into the Midwest Operating Engineers Welfare Fund.

Effective June 1, 2008, the Employer shall pay an additional Seventy-Five Cents (\$0.75) per hour for each hour for which the employee receives wages under the terms of this Agreement into the Midwest Operating Engineers Welfare Fund's Retiree Medical Savings Plan.

Effective June 1, 2009, the Employer shall pay Ten Dollars and Seventy Cents (\$10.70) per hour for each hour for which the employee receives wages under the terms of this Agreement into the Midwest Operating Engineers Welfare Fund.

Effective June 1, 2009, the Employer shall pay Ten Dollars and Seventy Cents (\$10.70) per hour for each hour worked by a Supervisor covered by this Agreement into the Midwest Operating Engineers Welfare Fund.

Effective June 1, 2009, the Employer shall pay an additional One Dollar (\$1.00) per hour for each hour for which the employee receives wages under the terms of this Agreement into the Midwest Operating Engineers Welfare Fund's Retiree Medical Savings Plan.

The Welfare Fund maintains a place of business at 6150 Joliet Road, Countryside, Illinois 60525, or at such other place designated by the Trustees. Contributions of the Employer shall be forwarded to such business office together with report forms supplied for such purpose not later than the tenth (10th) of the following month.

Contributions to the aforesaid Health and Welfare Fund shall not constitute or be deemed wages due to the employee.

It is understood and agreed that the Employer shall be bound to the terms and provisions of the Agreement and Declaration of Trust of the Midwest Operating Engineers Welfare Fund, and all amendments heretofore or hereafter made thereto, as though the same were fully incorporated herein.

If payment for contributions as defined above is not received by the Fund Office by the twentieth (20th) day of the month, the Employer shall be deemed to be in violation of this Agreement and the aforementioned Trust Agreement and shall be liable for contributions due, liquidated damages, interest, and any other cost of collection.

Anything herein contained to the contrary notwithstanding, an Employer required to make contributions on behalf of a "Supervisor" shall make contributions on the basis of one hundred sixty-eight (168) hours each month. The Employer may elect to report on the basis of actual hours worked per month provided the hours reported are in excess of one hundred sixty-eight (168) hours each month.

The parties recognize that individuals employed by corporations who are party to this Agreement may perform both bargaining unit and/or non-bargaining unit work. Certain of these employees receive compensation in such a manner that it is difficult to determine for purposes of fringe benefit contributions the precise number of hours which are spent performing bargaining unit work. It is therefore agreed that when an employee who is employed by a corporation, performs both bargaining unit work and/or non-bargaining unit work and who:

A. Is a shareholder, officer and/or director of the corporation or

B. Is a relative (father, mother, son, daughter, brother, sister, husband, wife, in-law) of a shareholder, officer and/or director of the corporation, the bargaining parties have agreed that any shareholder/relative reporting under this clause must report one hundred fifty (150) hours per month twelve (12) months a year, irrespective of the amount of work they perform or the amount of compensation they receive in any individual month. The Employer may elect to report on the basis of actual hours worked per month provided the hours reported are in excess of one hundred fifty (150) hours each month.

Corporate officers and their children will be exempt from this provision when they operate equipment doing bargaining unit work during an emergency such as fire, flood or to save life or property.

The exemptions provided herein do not relieve the Employer from the obligations of Article IX, Section 3 Regular Assigned Engineers of this Agreement.

FAMILY AND MEDICAL LEAVE ACT (FMLA) - the Employer of any employee who is eligible for and requests leave under the Family and Medical Leave Act (FMLA) shall promptly notify the Health and Welfare Fund Office, and before the leave commences, if possible. Employers shall make Health and Welfare contributions for any employee who is taking leave under the FMLA on the basis of forty (40) hours per week.

SECTION 2 - PENSION FUND

It is understood and agreed that there shall be continued a Trusteed Pension Plan known as the Midwest Operating Engineers Pension Fund.

Effective June 1, 2007, the Employer shall be liable to contribute Six Dollars and Five Cents (\$6.05) per hour for which the employee receives wages under the terms of this Agreement and shall pay Six Dollars and Five Cents (\$6.05) per hour for each hour worked by a Supervisor covered by this Agreement to the Fund Office which will be paid to the Midwest Operating Engineers Excess Benefit Fund in the amount (if

any) determined by the Trustees of the Excess Benefit Fund in accordance with the provisions of the Excess Benefit Plan, and the remainder, if any, will be paid to the Midwest Operating Engineers Pension Fund.

Effective June 1, 2008, the Employer shall be liable to contribute Six Dollars and Fifty-Five Cents (\$6.55) per hour for which the employee receives wages under the terms of this Agreement and shall pay Six Dollars and Fifty-Five Cents (\$6.55) per hour for each hour worked by a Supervisor covered by this Agreement to the Fund Office which will be paid to the Midwest Operating Engineers Excess Benefit Fund in the amount (if any) determined by the Trustees of the Excess Benefit Fund in accordance with the provisions of the Excess Benefit Plan, and the remainder, if any, will be paid to the Midwest Operating Engineers Pension Fund.

Effective June 1, 2009, the Employer shall be liable to contribute Seven Dollars and Five Cents (\$7.05) per hour for which the employee receives wages under the terms of this Agreement and shall pay Seven Dollars and Five Cents (\$7.05) per hour for each hour worked by a Supervisor covered by this Agreement to the Fund Office which will be paid to the Midwest Operating Engineers Excess Benefit Fund in the amount (if any) determined by the Trustees of the Excess Benefit Fund in accordance with the provisions of the Excess Benefit Plan, and the remainder, if any, will be paid to the Midwest Operating Engineers Pension Fund.

For Apprentices see schedule in Article XV, Section 2.

The Pension Fund has been established and shall be administered in accordance with the Labor Management Relations Act of 1947 as amended.

Payments accompanied by monthly reports on forms provided for the same are due in the Pension Office, 6150 Joliet Road, Countryside, Illinois 60525, or such other place as designated by the Trustees, not later than the tenth (10th) of the following month for the preceding month.

Contributions to the Pension Trust Fund shall not constitute or be deemed wages due to the employee.

It is understood and agreed that the Employer shall be bound by the terms and provisions of the Agreement and Declaration of Trust of the Midwest Operating Engineers Pension Fund, and all amendments theretofore or hereafter made thereto, as though the same were fully incorporated herein.

If payment for contributions as defined above is not received by the Fund Office by the twentieth (20th) day of the month, the Employer shall be deemed to be in violation of this Agreement and the aforementioned Trust Agreement and shall be liable for contributions due, liquidated damages, interest, and any other cost of collection.

Anything herein contained to the contrary notwithstanding, an Employer required to make contributions on behalf of a "Supervisor" shall make contributions on the basis of one hundred sixty-eight (168) hours each month. The Employer may elect to report on the basis of actual hours worked per month provided the hours reported are in excess of one hundred sixty-eight (168) hours each month.

The parties recognize that individuals employed by corporations who are party to this Agreement may perform both bargaining unit and/or non-bargaining unit work. Certain of these employees receive compensation in such a manner that it is difficult to determine for purposes of fringe benefit contributions the precise number of hours which are spent performing bargaining unit work. It is therefore agreed that when an employee who is employed by a corporation, performs both bargaining unit work and/or non-bargaining unit work and who:

A. Is a shareholder, officer and/or director of the corporation or

B. Is a relative (father, mother, son, daughter, brother, sister, husband, wife, in-law) of a shareholder, officer and/or director of the corporation, the bargaining parties have agreed that any shareholder/relative reporting under this clause must report one hundred fifty (150) hours per month twelve (12) months a year, irrespective of the amount of work they perform or the amount of compensation they receive in any individual month. The Employer may elect to report on the basis of actual hours worked per month provided the hours reported are in excess of one hundred fifty (150) hours each month.

Corporate officers and their children will be exempt from this provision when they operate equipment doing bargaining unit work during an emergency such as fire, flood or to save life or property.

The exemptions provided herein do not relieve the Employer from the obligations of Article IX, Section 3 Regular Assigned Engineers of this Agreement.

Commencing October 1, 2000, the Employer agrees to make payments to the Midwest Operating Engineers Pension Fund, in the amount (if any) determined by the Trustees of the Excess Benefit Fund. Such contributions to the Excess Benefit Fund shall be an offset against the amounts otherwise due to be

paid by the Employer to the Midwest Operating Engineers Pension Fund pursuant to the first paragraph of this Section, and the amount the Employer is obligated by this Agreement to contribute to the Midwest Operating Engineers Pension Fund shall be reduced by the amounts contributed to the Excess Benefit Fund pursuant to the determination of the Trustees of the Excess Benefit Fund. The parties agree that the Midwest Operating Engineers Excess Benefit Fund (a) will be a non-qualified defined contribution plan, (b) shall only provide benefits for people who are, at the time of benefit payments, retired under the Midwest Operating Engineers Pension Fund and who had benefit payments reduced in prior years on account of Internal Revenue Code Section 415, and (c) that such Excess Plan benefits will be payable only when and to the extent determined by the Trustees of the Excess Benefit otherwise rendered moot by legislative action, and all benefit payments under the Midwest Operating Engineers Pension Fund that were previously reduced on account of Section 415 have been made up through the Excess Benefit Fund or otherwise, this paragraph shall have neither force nor effect. In such event, the remaining articles of this collective bargaining agreement shall be unaffected, and shall otherwise remain in full force and effect.

SECTION 3 - RETIREMENT ENHANCEMENT FUND

It is understood that a trustee pension plan known as the Midwest Operating Engineers Retirement Enhancement Fund has been established by the Union and Employer Associations party to this Agreement.

Effective June 1, 2008, the Employer shall contribute Fifty Cents (\$0.50) per hour for each hour for which the employee receives wages under the terms of this Agreement into the Midwest Operating Engineers Retirement Enhancement Fund.

Effective June 1, 2009, the Employer shall contribute One Dollar (\$1.00) per hour for each hour for which the employee receives wages under the terms of this Agreement into the Midwest Operating Engineers Retirement Enhancement Fund.

The Retirement Enhancement Fund has been established and shall be administered in accordance with the Labor Management Relations Act of 1947, as amended, and the Employee Retirement Income Security Act of 1974, as amended.

Payments accompanied by monthly reports on forms provided for same are due in the Administration Office, 6150 Joliet Road, Countryside, Illinois 60525, or such other place as designated by the Trustees, not later than the tenth (10th) of the following month for the preceding month.

Contributions to the Retirement Enhancement Fund shall not constitute or be deemed wages due to the employee.

It is understood and agreed that the Employer shall be bound by the terms and provisions of the Agreement and Declaration of Trust of the Midwest Operating Engineers Retirement Enhancement Fund, and all amendments theretofore or hereafter made thereto, as though same were fully incorporated herein.

If payment for contributions as defined above is not received by the Fund Office by the twentieth (20th) day of the month, the Employer shall be deemed to be in violation of this Agreement and the aforementioned Trust Agreement and shall be liable for contributions due, liquidated damages, interest, and any other cost of collection.

Anything herein contained to the contrary notwithstanding, an Employer required to make contributions on behalf of a "Supervisor" shall make contributions on the basis of one hundred sixty-eight (168) hours each month. The Employer may elect to report on the basis of actual hours worked per month provided the hours reported are in excess of one hundred sixty-eight (168) hours each month.

The parties recognize that individuals employed by corporations who are party to this Agreement, may perform both bargaining unit and/or non-bargaining unit work. Certain of these employees receive compensation in such a manner that it is difficult to determine for purposes of fringe benefit contributions the precise number of hours which are spent performing bargaining unit work. It is therefore agreed that when an employee who is employed by a corporation, performs both bargaining unit work and/or non-bargaining unit work and who:

- A.** Is a shareholder, officer and/or director of the corporation or
- B.** Is a relative (father, mother, son, daughter, brother, sister, husband, wife, in-law) of a shareholder, officer and/or director of the corporation, the bargaining parties have agreed that any shareholder/relative reporting under this clause must report one hundred fifty (150) hours per month twelve (12) months a year, irrespective of the amount of work they perform or the amount of compensation they receive in any individual month. The Employer may elect to report on the basis of actual hours worked per month provided the hours reported are in excess of one hundred fifty (150) hours each month.

Corporate officers and their children will be exempt from this provision when they operate equipment doing bargaining unit work during an emergency such as fire, flood or to save life or property.

The exemptions provided herein do not relieve the Employer from the obligations of Article IX, Section 3 Regular Assigned Engineers of this Agreement.

SECTION 4 - VACATION FUND

Effective the 1st day of June, 2007, each Employer bound hereby shall pay One Dollar and Ninety Cents (\$1.90) per hour for each hour wages are received by an employee covered by this Agreement into the Local 150 I.U.O.E. Trusteed Vacation Savings Plan.

For Apprentices, see schedule in Article XV, Section 2.

In computing the above amounts, the Employer is required to add the amount per hour to the employee's gross wages and then deduct the Social Security and Withholding tax from the gross figure on each check. The full amount shall then be set aside for remittance to the Vacation Savings Plan.

Each Employer bound hereby irrevocably appoints as his representative on the Board of Trustees as are named in the Agreement and Declaration of Trust as Employer Trustees and their successors duly appointed as therein set forth, and agrees to be bound by all the terms and provisions of the Agreement and Declaration of Trust, Local 150 I.U.O.E. Vacation Savings Plan, and all amendments heretofore or hereafter made thereto, as though the same were fully incorporated herein.

Payments accompanied by monthly reports on forms provided for same are due in the Vacation Savings Plan Office, 6150 Joliet Road, Countryside, Illinois 60525, not later than the tenth (10th) day of the following month for the preceding month. Report forms are available at the above address. However, if payment is not in by the twentieth (20th) day of the month, it shall be considered a violation of this Agreement and the aforementioned Trust Agreement and shall be liable for contributions due, liquidated damages, interest, and any other cost of collections.

Additional information and Employer code numbers can be obtained by the Vacation Savings Office, 6150 Joliet Road, Countryside, Illinois 60525.

ARTICLE XVII

APPRENTICESHIP AND SKILL IMPROVEMENT FUND

A Trustees Apprenticeship and Skill Improvement Fund has been created and is known as the Operating Engineers Local 150 Apprenticeship Fund.

Effective June 1, 2007, the Employer shall pay Seventy Cents (\$0.70) for each hour the employee receives wages under the terms of this Agreement into the aforementioned Apprenticeship Fund.

Effective June 1, 2008, the Employer shall pay One Dollar (\$1.00) for each hour the employee receives wages under the terms of this Agreement into the aforementioned Apprenticeship Fund.

Effective June 1, 2009, the Employer shall pay One Dollar and Twenty-Five Cents (\$1.25) for each hour the employee receives wages under the terms of this Agreement into the aforementioned Apprenticeship Fund.

It is understood and agreed that the Employer shall be bound by the terms and provisions of the Agreement and Declaration of Trust of the Apprenticeship Fund, and all amendments heretofore or hereafter made thereto, as though the same were fully incorporated herein.

The Employer further agrees to be bound by the terms of the Apprenticeship Standards established by the Joint Apprenticeship Training Committee of the Northern Illinois and Northern Indiana Apprenticeship and Skill Improvement Program, as approved by the United States Department of Labor, Bureau of Apprenticeship Training.

The Apprenticeship Fund has been established and shall be administered in accordance with the Labor Management Relations Act of 1947, as amended, and all other applicable Federal and State Laws.

Contributions of the Employer together with report forms supplied for such purpose are due in the Apprenticeship Fund Office not later than the tenth (10th) day of the following month.

Contributions to the aforesaid Apprenticeship Fund shall not constitute or be deemed wages due to the employee.

The sole liability of the Employer to the Apprenticeship Fund shall be the payment of hourly contributions as set forth in this Article, provided, however, that nothing herein shall be interpreted to release the Employer from its obligations under the Apprenticeship Standards as set forth above.

If payment for contributions as defined above is not received by the Fund Office by the twentieth (20th) day of the month, the Employer shall be deemed to be in violation of this Agreement and the aforementioned Trust Agreement and shall be liable for contributions due, liquidated damages, interest, and any other cost of collection.

Anything herein contained to the contrary notwithstanding, an Employer required to make contributions on behalf of a "Supervisor" shall make contributions on the basis of one hundred sixty-eight (168) hours each month. The Employer may elect to report on the basis of actual hours worked per month provided the hours reported are in excess of one hundred sixty-eight (168) hours each month.

The parties recognize that individuals employed by corporations who are party to this Agreement, may perform both bargaining unit and/or non-bargaining unit work. Certain of these employees receive compensation in such a manner that it is difficult to determine for purposes of fringe benefit contributions the precise number of hours which are spent performing bargaining unit work. It is therefore agreed that when an employee who is employed by a corporation, performs both bargaining unit work and/or non-bargaining unit work and who:

A. Is a shareholder, officer and/or director of the corporation or

B. Is a relative (father, mother, son, daughter, brother, sister, husband, wife, in-law) of a shareholder, officer and/or director of the corporation, the bargaining parties have agreed that any shareholder/relative reporting under this clause must report one hundred fifty (150) hours per month twelve (12) months a year, irrespective of the amount of work they perform or the amount of compensation they receive in any individual month. The Employer may elect to report on the basis of actual hours worked per month provided the hours reported are in excess of one hundred fifty (150) hours each month.

Corporate officers and their children will be exempt from this provision when they operate equipment doing bargaining unit work during an emergency such as fire, flood or to save life or property.

The exemptions provided herein do not relieve the Employer from the obligations of Article IX, Section 3 Regular Assigned Engineers of this Agreement.

ARTICLE XVIII

A. DUES CHECK-OFF. Upon receipt of a written check-off authorization form from an employee, the Employer agrees to deduct each week the applicable initiation fees and monthly dues uniformly required for obtaining and maintaining membership in the Union from the pay of each employee covered by this Agreement and shall remit the same to the Union, no later than the tenth (10th) day of each month, together with an itemized statement of such deductions. No deductions shall be made which are prohibited by applicable law. Payments accompanied by monthly reports on forms provided shall be submitted to the Midwest Operating Engineers Fringe Benefit Fund, 6150 Joliet Road, Countryside, Illinois 60525. Report forms are available at the above address.

However, if payment is not received by the twentieth (20th) day of the month, it shall be considered a violation of this Agreement, and the Union shall be entitled for all contributions due, liquidated damages, interest, and any other cost of collections.

It is the intention of the parties that such deductions shall comply with the requirements of the Section 302(c) (4) of the Labor Management Relations Act of 1947, as amended, and that such deductions shall be made only pursuant to written assignments from each employee on whose account such deductions are made, which assignment shall not be irrevocable for a period of more than one (1) year, or beyond the termination date of this Agreement, whichever occurs sooner.

The Union agrees to indemnify and hold harmless the Employer, from any claim, suit, cause of action, or otherwise as regards a creation of the Dues Deduction, its administration or any act or action in connection therewith and such indemnity and agreement to hold harmless shall include the payment of costs and attorney's fees in behalf of the beneficiaries of such indemnity.

B. FEDERAL PAC CHECK-OFF. The Employer will deduct Five Cents (\$0.05) for each hour that the employee receives wages under the terms of this Agreement on the basis of individually signed voluntarily authorized deduction forms and shall pay over the amount so deducted to the International Union of Operating Engineers Political Action Committee ("IUOE PAC"), 6200 Joliet Road, Countryside, Illinois 60525. It is agreed that these authorized deductions for the IUOE PAC are not conditions of membership in the International Union of Operating Engineers, Local 150, shall be remitted at the same time as required for the

monthly pension and welfare payments on a separate check made payable to the IUOE PAC at the above address. The Employer shall deduct a processing fee each month from the total amount to be transmitted to the IUOE PAC to be calculated at the Illinois Department of Revenue standard which is currently 1.75 percent.

The Union agrees to indemnify and hold harmless the Employer from any claim, suit, cause of action, or otherwise with regard to creation of this dues deduction, its administration, or any act or action in connection therewith, and such indemnity and agreement to hold harmless shall include the payment of costs and attorney's fees on behalf of the beneficiaries of such indemnity.

ARTICLE XIX INDUSTRY ADVANCEMENT FUND AND CONSTRUCTION INDUSTRY RESEARCH AND SERVICE TRUST FUND

Effective June 1, 2007, the Employer shall pay Eighteen Cents (\$0.18) per hour for each hour for which employees and supervisors receive wages under the terms of this Agreement into the Construction Industry Research and Service Trust Fund ("CRF").

Effective June 1, 2008, the Employer shall pay Twenty-Three Cents (\$0.23) per hour for each hour for which employees and supervisors receive wages under the terms of this Agreement into the CRF.

Effective June 1, 2009, the Employer shall pay Twenty-Eight Cents (\$0.28) per hour for each hour for which employees and supervisors receive wages under the terms of this Agreement into the CRF.

Contributions of the Employer shall be forwarded to CRF in care of the Midwest Operating Engineers Fringe Benefit Funds, 6150 Joliet Road, Countryside, Illinois 60525 ("MOE"), together with report forms supplied for such purposes not later than the tenth (10th) day of the following month. It is understood and agreed that MOE will administer the collection and distribution of the CRF contributions and will receive a reasonable fee for that service, subject to approval of the Trustees of the CRF. The contributions to the aforesaid Construction Industry Research and Service Trust Fund shall not constitute or be deemed wages due to the employee.

Of the CRF contributions, Seven Cents (\$0.07) per hour for each hour for which contributions are made will be distributed to the MARBA Industry Advancement Fund (MARBA IAF), a not-for-profit corporation, and Excavators, Inc., a not-for-profit corporation, to be divided with sixty percent (60%) to MARBA IAF and forty percent (40%) to Excavators, Inc.; and One Cent (\$0.01) per hour for each hour for which contributions are made will be distributed to the Construction Industry Service Corporation ("CISCO"), a not-for-profit corporation. The remaining Ten Cents (\$0.10) effective June 1, 2007; Fifteen Cents (\$0.15) effective June 1, 2008; and Twenty Cents (\$0.20) effective June 1, 2009, per hour for each hour for which contributions are made will be distributed by the CRF Trustees in accordance with the power and authority granted to them in the applicable CRF Agreement and Declaration of Trust.

Anything herein contained to the contrary notwithstanding, there is specifically excluded from the purposes of the CRF and/or any of the entities to which it distributes contributions, the right to use any of its funds for lobbying in support of anti-labor legislation and/or to subsidize contractors during a period of work stoppage or strikes. MARBA IAF, Excavators, Inc. CISCO and all other recipients of CRF funds shall report annually to the CRF, giving a complete review of their activities and the activities of any of their members, including a certified audit showing the CRF disbursements. The CRF shall report annually to Local 150, IUOE, giving a complete review of its activities and a certified audit showing the Fund disbursements. Said review and audit to be furnished no later than May 1st of each year.

It is understood and agreed that the Employer shall be bound by the terms and provisions of the Agreement and Declaration of Trust of the Construction Industry Research and Service Trust Fund, and all amendments heretofore or hereafter thereto, as though the same were fully incorporated herein.

If payment for contributions as defined above is not received by the Fund Office by the twentieth (20th) day of the month, the Employer shall be deemed to be in violation of this Agreement and the aforementioned Trust Agreement and shall be liable for contributions due, liquidated damages, interest and any other costs of collection.

Anything herein contained to the contrary notwithstanding, an Employer required to make contributions on behalf of a "Supervisor" shall make contributions on the basis of one hundred sixty-eight (168) hours each month. The Employer may elect to report on the basis of actual hours worked per month provided the hours reported are in excess of one hundred sixty-eight (168) hours each month.

The parties recognize that individuals employed by corporations who are party to this Agreement, may perform both bargaining unit and/or non-bargaining unit work. Certain of these employees receive compensation in such a manner that it is difficult to determine for purposes of fringe benefit contributions the precise number of hours which are spent performing bargaining unit work. It is therefore agreed that when an employee who is employed by a corporation, performs both bargaining unit work and/or non-bargaining unit work and who:

A. Is a shareholder, officer and/or director of the corporation or

B. Is a relative (father, mother, son, daughter, brother, sister, husband, wife, in-law) of a shareholder, officer and/or director of the corporation, the bargaining parties have agreed that any shareholder/relative reporting under this clause must report one hundred fifty (150) hours per month twelve (12) months a year, irrespective of the amount of work they perform or the amount of compensation they receive in any individual month. The Employer may elect to report on the basis of actual hours worked per month provided the hours reported are in excess of one hundred fifty (150) hours each month.

Corporate officers and their children will be exempt from this provision when they operate equipment doing bargaining unit work during an emergency such as fire, flood or to save life or property.

The exemptions provided herein do not relieve the Employer from the obligations of Article IX, Section 3 Regular Assigned Engineers of this Agreement.

The administration of this Fund shall be solely in the hands of the CRF and no Employer shall pay or deliver any funds to any representative of his employees. The Fund and the Trustees thereof agree to indemnify and hold harmless the Union, its officers, agents, representatives and members from any claim, suit, cause of action, or otherwise as regards a creation of the Fund, its administration or any act or action in connection therewith, and such indemnity and agreement to hold harmless shall include the payment of costs and attorneys' fees in behalf of the beneficiaries of such indemnity.

The Association agrees to indemnify and hold harmless the Union, its Officers, Agents, Representatives and Members from any claim, suit, cause of action, or otherwise as regards the collection and transmission of Industry Advancement Fund collections.

ARTICLE XX

SECTION 1 - PENALTY FOR FAILURE TO PAY PENSION AND/OR HEALTH AND WELFARE AND/OR VACATION CONTRIBUTIONS AND/OR DUES CHECK OFF AND/OR JOINT GRIEVANCE COMMITTEE AND/OR ARBITRATION AWARD

If any Employer upon forty-eight (48) hours written notice of default to the Employer fails to pay pension and/or health and welfare and/or vacation and/or Apprenticeship and/or dues check off contributions, and/or a signed grievance settlement, and/or Joint Grievance Committee award, and/or an arbitration award (if after ninety (90) days of the entry of the Joint Grievance Committee or arbitration award, the award remains unpaid), the arbitration procedure herein provided for shall become inoperative and the Union shall be entitled to resort to all legal and economic remedies, including the right to strike and picket until such failure to pay has been corrected.

Disputes as to the effectiveness or validity of employee dues deduction authorizations shall not subject a contractor to any right to strike provided for in this Article. The Union must be advised specifically of any such dispute within forty-eight (48) hours of written notice.

SECTION 2 - PENALTY FOR FAILURE TO PAY WAGES

If any Employer fails to pay wages, the arbitration procedure herein provided for shall become inoperative and the Union shall be entitled to resort to all legal and economic remedies, including the right to strike and picket until such failure to pay has been corrected including penalties set out in Article XVI herein.

This clause shall be inoperative if the amount of wages is bonafidely disputed. In such instance, the Employer shall then pay the wages admitted to be due and the balance shall be settled by the arbitration procedure as provided herein.

SECTION 3 - BONDING OF EMPLOYER

The Union, may at its discretion, demand a payment bond of any Employer guaranteeing payment of all earnings, vacation savings, welfare and pension benefit contributions which may become due.

SECTION 4 - LEGITIMATE PICKET LINE

It shall not be a violation of this Agreement and it shall not be cause for discharge or disciplinary action in the event an employee refuses to enter upon any property involved in a legitimate labor dispute or refuses to go through or work behind any picket line, including the picket line of the Union party to this Agreement and including picket lines at the Employer's place or places of business. Furthermore, an employee may refuse to cross any picket line when he fears that bodily harm may be done to him.

ARTICLE XXI CONTRACT REOPENER

In the event that the provisions of the Davis-Bacon Act, 40 U.S.C. & 276(a) and/or the provisions of the State of Illinois Prevailing Wage Act, 820 ILCS & 130 et. seq., are repealed or substantially modified in a manner which adversely affects the ability of signatory Employers to compete for State or Federal work, the parties to this Agreement agree to immediately reopen the Agreement and negotiate appropriate changes in terms and conditions of employment to maintain contractor competitiveness for such work. In the event no agreement is reached after sixty (60) days of the commencement of such negotiations, then either party may resort to self-help, including but not limited to strikes, lockouts and unilateral implementation.

ARTICLE XXII SAVINGS CLAUSE

Any provision contained herein that is contrary to or held to be in violation of the Labor Management Relations Act of 1947, or any federal or state law now in force or hereafter enacted, or hereafter becoming effective shall be void and of no force or effect, and this contract shall be construed as if said provision herein were not a part hereof, it being intended, however, that the other provisions of this contract shall not be affected thereby.

It is further agreed that should compliance with any federal or state law, or amendment thereof, or any order or regulation issued thereunder, now or hereafter in force and effect prohibit the carrying out of any of the provisions of this Agreement, then to the extent of such deviation or prohibition, this Agreement shall be deemed to have been automatically amended, effective on the effective date of such law, order or regulation.

Such amendment to this contract shall remain in effect only so long as said law, amendment, order or regulation continues in force, or until the expiration of this Agreement, whichever event shall first occur.

ARTICLE XXIII ENTIRE AGREEMENT OF THE PARTIES

This represents the entire Agreement of the parties, it being understood that there is no other agreement or understanding, either oral or written. The Employer understands that the Union is a fraternal society and as such, and in keeping with the provisions of the Labor Management Relations Act of 1947, as amended, has the right to prescribe its own rules and regulations with respect to the acquisition or retention of membership in the Union or with respect to any other matters for its own use. However, such rules or regulations whether contained in a by-laws, constitution or otherwise shall have no effect directly or indirectly upon this collective bargaining agreement, any employment relationship or the relationship between the parties.

EFFECTIVE DATE - this Agreement shall become effective the 1st day of June, 2007, except as otherwise provided herein and remain in full force and effect until the 31st day of May, 2010, and shall thereafter continue from year to year, unless at least sixty (60) days prior to the expiration date, or as thereafter extended, either party hereto shall notify the other in writing of its intention to terminate. It is contemplated that the parties will, in said sixty (60) days period meet with each other to negotiate a new agreement.

IN WITNESS WHEREOF, the parties have executed this Agreement this 21st day of February, 2007.

REPRESENTING THE
MID-AMERICA REGIONAL BARGAINING
ASSOCIATION on behalf of its
members:

Joseph E. Benson
David J. Rock
John K. Vignocchi

REPRESENTING THE:
INTERNATIONAL UNION OF OPERATING
ENGINEERS, LOCAL 150, AFL-CIO

William E. Dugan
Steven M. Cisco
James M. Sweeney

**Illustrations and Definition of Piggybacking
and Staging of Electric Submersible Pumps as
applied in the Heavy and Highway and Building Agreement**

Electric Submersible pumps may be physically connected to each other (piggyback) without causing any increase in discharge as calculated under this section.

Discharge of Electric Submersible pumps which are not piggy- backed but which are physically connected by hose, pipe, etc. or are otherwise staged shall be calculated separately and totaled in calculating total discharge under this section. (See illustration)

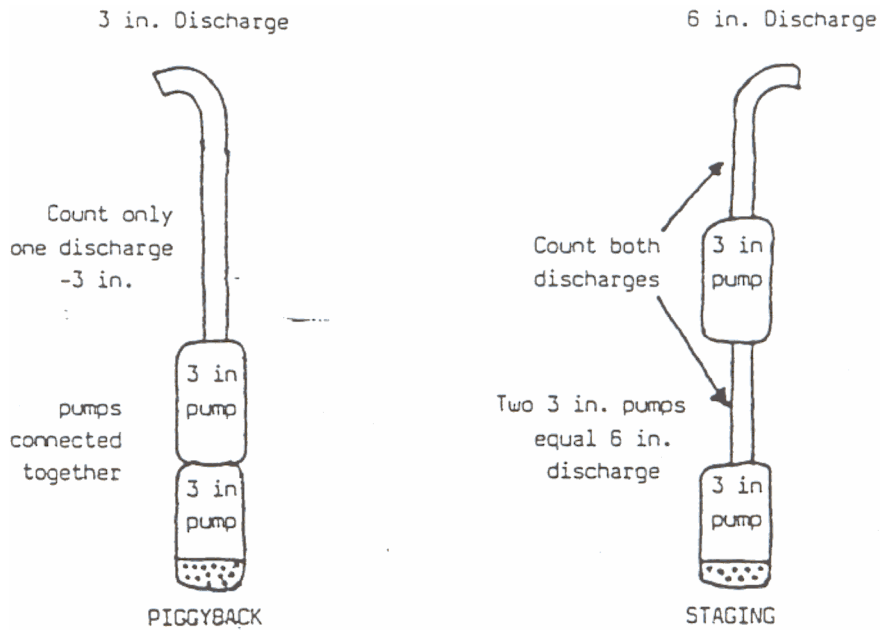

REPRESENTING THE:
MID-AMERICA REGIONAL
BARGAINING ASSOCIATION

Joseph E. Benson
David J. Rock
John K. Vignocchi

REPRESENTING THE:
I.U.O.E. LOCAL UNION 150

William E. Dugan
Steven M. Cisco
James M. Sweeney

MEMORANDUM OF CLARIFICATION regarding Application of Illinois Building/Heavy and Highway and Underground Agreement of Local 150 I.U.O.E. which expire on June 30, 1981 in their application to:

SEWAGE PLANTS

This memorandum based on a site visit to the Aurora Sewage Plant, Montgomery, Illinois (See minutes Case No. 79-17 and Joint Grievance Committee Minutes, January 4, 1980,) (A.J. Lowe Co. vs. Local 150 I.U.O.E.) is effective July 15, 1980.

- (1) All sewer and watermain pipe outside of structure wall or building wall to be installed under the Heavy and Highway and Underground Agreement.
- (2) All sewer and watermain pipe inside a structure wall or building wall to be installed under the Illinois Building Agreement.
- (3) All air feed pipe and chemical feed pipe, even though installed underground, shall be installed under the Illinois Building Agreement.

MID-AMERICA REGIONAL
BARGAINING ASSOCIATION

Joseph E. Benson
David J. Rock
John K. Vignocchi

LOCAL 150 INTERNATIONAL
UNION OF OPERATING ENGINEERS

William E. Dugan
Steven M. Cisco
James M. Sweeney

MEMORANDUM OF AGREEMENT

COMPETITION COMMITTEE

The Union and the Association together shall create a Competition Committee.

This Committee shall consist of an equal number of members representing the Employer and Union with no less than three (3) persons from each group. The Union and/or Association may appoint alternate members.

The purpose of this committee shall be to consider and implement under appropriate circumstance and based on adequate economic justification modification of this Agreement to apply to specific projects and/or geographic areas to assure continued work opportunities for employees working under this Agreement.

FOR THE ASSOCIATION:

Joseph E. Benson
David J. Rock
John K. Vignocchi

FOR THE UNION:

William E. Dugan
Steven M. Cisco
James M. Sweeney

MEMORANDUM OF AGREEMENT

WORK CONTINUATION PROGRAM

In an effort to maintain a positive labor relations environment and a competitive union construction market in the Metropolitan Chicago Area, the contractor members of the BAC, CCA, COB, IRBA, LCCDA and UCA, represented by Mid America Regional Bargaining Association (MARBA), their collective bargaining representative, and International Union of Operating Engineers Local 150 now agree as follows:

- 1.** The parties agree to exchange contract proposals at least 90 days prior to the expiration date of the contract.
- 2.** The parties agree to meet on a regular basis (to be determined) at least 30 days before expiration.
- 3.** After the expiration date, and for 30 days following, the parties will meet Mondays, Wednesdays, and Fridays for a designated period of time (to be determined) until an agreement is reached.
- 4.** Any time after expiration date an agreement is reached it shall be retroactive back to the day after expiration.
- 5.** If after 30 days from expiration no agreement is reached, the Union retains the right to strike.

FOR THE ASSOCIATION:

Joseph E. Benson
David J. Rock
John K. Vignocchi

FOR THE UNION:

William E. Dugan
Steven M. Cisco
James M. Sweeney

**LETTER OF UNDERSTANDING BETWEEN I.U.O.E. LOCAL 150 AND
MID-AMERICA BARGAINING ASSOCIATION PERTAINING TO THE
HEAVY & HIGHWAY & UNDERGROUND AGREEMENT,
DISTRICTS 1, 2 & 3
DATED JUNE 1, 1987**

Based on Article VIII, Section 1 where it says, "in the event a dispute arises over the applicability of preparation time, or oiler (Apprentice) requirements, due to the introduction of new models of machines or due to the manufacturer's or employer's de-rating or re-classification of any machine's size, lifting capacity, bucket capacity, or weight, a committee comprised of an equal number of representatives of the Union and the Association signatory hereto shall meet to make an equitable decision of the machine in question".

A dispute has arisen on a mining machine as to whether it is 5 ft. or over (Article VII, Section 10). The dispute is where to measure the machine to arrive at its proper size. After examining two like machines and arriving at two different diameters it was determined by the committee that the diameter of the shield should be the determining factor since it is the only part of the machine that the measurement remains constant.

FOR THE ASSOCIATION:

David J. Rock
Joseph E. Benson
John K. Vignocchi

FOR THE UNION:

William E. Dugan
Steven M. Cisco

**MEMORANDUM OF AGREEMENT
TRENCHING MACHINES**

**MID-AMERICA REGIONAL BARGAINING ASSOCIATION
LABOR MANAGEMENT COMMITTEE**

A question has been raised by an Employer as to the intent of the word "trenching" as listed in Article XV "Classifications" of the Heavy and Highway and Underground Agreement, Districts 1, 2 and 3, dated June 1, 1987.

The Employer feels the intent of this classification in Class I was for large wheel type trenching machines and does not include small chain type trenchers. The Employer asks that under Article I, Section 2 Unlisted Equipment that chain type trenching machines be listed in Class IV.

After pictures and manufacturers brochures were reviewed by the Committee, the Committee by majority vote determined that chain type trenching machines, 12" and under, when used digging trenches for installation of telephone cable, TV cable, electric cable and natural gas services from the distribution line to the residence shall be included in Class IV.

FOR: MID-AMERICA REGIONAL
BARGAINING ASSOCIATION

Joseph E. Benson.
David J. Rock
John K. Vignocchi

FOR: INTERNATIONAL UNION OF
OPERATING ENGINEERS
LOCAL 150, AFL-CIO

William E. Dugan
Steven M. Cisco

**LETTER OF UNDERSTANDING
BETWEEN I.U.O.E. LOCAL 150 AND
MID-AMERICA REGIONAL BARGAINING ASSOCIATION
PERTAINING TO THE
HEAVY & HIGHWAY & UNDERGROUND AGREEMENT,
DISTRICTS 1, 2 & 3
DATED JUNE 1, 2001**

A dispute has arisen over the interpretation of Article V, Section 2 wage payment specifically where it reads "payday shall be once each week on a specified day during work hours", also Article III, Section 4A payday for employees during show-up time period and 4B payday for employees who are not required to work during call off.

It is the finding of the Committee that payroll checks delivered by mail, or other means, or direct deposit, to the employees' place of residence, or financial institution on the prescribed payday is an acceptable means of wage payment.

FOR THE ASSOCIATION:

David J. Rock
Joseph E. Benson
John K. Vignocchi

FOR THE UNION:

William E. Dugan
Steven M. Cisco

**ARBITRATION AWARD
LUNCH PERIOD**

After careful study of the record in its entirety, including all of the evidence and argument presented by both parties, the Arbitrator renders the following Award:

The employer did not violate Article III, Section 1, Subsection (c) "LUNCH PERIOD" of the Heavy, Highway and Underground Agreement when, on its Illinois Toll road jobsite, it operated a second shift utilizing some, but not all, machines utilized on the first shift and paid a one-half hour lunch period only to those first-shift employees whose machines were also actually operated on the second shift, rather than pay all first-shift employees a one-half hour lunch period.

The grievance is denied.

Signed by me at Milwaukee, Wisconsin, this 23rd day of January, 1989.

Steven Briggs

The above decision by Steven Briggs of the American Arbitration Association is the result of a May 24, 1989 meeting of the MARBA Labor Management Committee. At this meeting the Committee was unable to reach a majority decision and submitted the dispute to arbitration.

CRUSHING OPERATIONS

One (1) Operator (Class I) shall be assigned to crushing operations, regardless of configuration or mode of power*, when the operator is producing only one product at a time.

Two (2) Operators (Class I) shall be assigned to crushing operations, regardless of configuration or mode of power*, when the operation is producing more than one product at a time.

Scrap iron, steel or rebar and wood, petromat or other debris shall not be considered products.

The following will apply for either single or multiple product configurations:

The loader feeding the crusher will be operated by one (1) Operator (Class I). Any Crusher Operator listed above not in control of the plant, other than start up, may not operate the primary loader feeding the crusher, but may operate another machine (i.e. a second loader, dozer, backhoe, breaker, wrecking ball breaker) directly associated with the crushing operation. The operation of any additional support equipment listed above will be assigned to Operators (Class I).

Additional "groundman" personnel assigned by the Employer to assist in the operation will be paid at the Class V rate of pay. A "groundman" will pick steel, burn with torches, shovel, sweep, grease and clean up around equipment, operate skid-steer loader, wash and maintain equipment and any other work incidental to the crushing operation.

*Crushing operation configuration includes, but is not limited to, down power or generators, crushers, conveyors, screen plants, wash plant, compressors and breaker attachments.

Dated: May 29, 2003

ASPHALT PLANT OPERATIONS

Asphalt plants, regardless of configuration*, will require only one (1) Operator (Class I) and only one (1) apprentice/oiler when the plant is in operation.

Loaders at the plant will require an Operator in accordance with the contract.

*Asphalt plant configuration includes, but is not limited to, conveyors, screens or scalpers, compressors and motors. Any equipment listed here that is operated at the plant as stand alone equipment, not part of the plant configuration, will require an operator in accordance with the contract.

Dated: May 29, 2003

CONCRETE PLANTS

Concrete plants, regardless of configuration or mode of power*, will require one (1) Plant Operator (Class I) and one (1) Assistant Plant Operator (Class I).

The Assistant Plant Operator will be responsible for assisting in maintenance work on and around the plant. This operator can also be used to assist in the operation of the plant or as a cement tender (unloading blimps) at the discretion of the Employer.

Loaders at the plant will require an Operator in accordance with the contract.

Boilers, when used, will require an Operator (Class III).

*Concrete plant configuration includes, but is not limited to, down power of generators, conveyors, compressors, motors and dust collection system. Any equipment listed here that is operated at the plant as stand alone equipment, not part of the plant configuration, will require an operator in accordance with the contract.

Dated: May 29, 2003

JOINT LABOR MANAGEMENT COMMITTEE
UNIFORM DRUG/ALCOHOL ABUSE PROGRAM

I. POLICY STATEMENT

The parties recognize the problems created by drug and alcohol abuse and the need to develop prevention and treatment programs. _____ (Company Name) _____, and the signatory unions seek to protect people and property, and to provide a safe working environment. The purpose of the following program is to establish and maintain a drug free, alcohol free, safe, healthy work environment for all its employees.

II. DEFINITIONS

A. Company Premises - The term "Company Premises" as used in this policy includes all property, facilities, land, buildings, structures, automobiles, trucks and other vehicles owned, leased or used by the company. Construction job sites for which the company has responsibility are included.

B. Prohibited Items & Substances - Prohibited substances include illegal drugs (including controlled substances, look alike drugs and designer drugs), alcoholic beverages, and drug paraphernalia in the possession of or being used by an employee on the job.

C. Employee - Individuals, who perform work for _____ Company Name _____, including, but not limited to, management, supervision, engineering, craft workers and clerical personnel.

D. Accident - Any event resulting in injury to a person or property to which an employee, or contractor/contractor's employee, contributed as a direct or indirect cause.

E. Incident - An event which has all the attributes of an accident, except that no harm was caused to person or property.

F. Reasonable Cause - Reasonable cause shall be defined as excessive tardiness, excessive absenteeism, and erratic behavior such as noticeable imbalance, incoherence, and disorientation.

III. CONFIDENTIALITY

A. All parties to this policy and program have only the interests of Employees in mind, therefore, encourage any employee with a substance abuse problem to come forward and voluntarily accept our assistance in dealing with the illness. An employee assistance program will provide guidance and direction for you during your recovery period. If you volunteer for help, the company will make every reasonable effort to return you to work upon your recovery. The company will also take action to assure that your illness is handled in a confidential manner.

B. All actions taken under this policy and program will be confidential and disclosed only to those with a "need to know".

C. When a test is required, the specimen will be identified by a code number, not by name, to insure confidentiality of the donor. Each specimen container will be properly labeled and made tamper proof. The donor must witness this procedure.

D. Unless an initial positive result is confirmed as positive, it shall be deemed negative and reported by the laboratory as such.

E. The handling and transportation of each specimen will be properly documented through the strict chain of custody procedures.

IV. RULES-DISCIPLINARY ACTIONS-GRIEVANCE PROCEDURES

1. Rules - All Employees must report to work in a physical condition that will enable them to perform their jobs in a safe and efficient manner. Employees shall not:
 - a. Use, possess, dispense or receive prohibited substances on or at the job site; or
 - b. Report to work with any measurable amount of prohibited substances in their system.

2. Discipline - When the company has reasonable cause to believe an employee is under the influence of a prohibited substance, for reasons of safety, the employee may be suspended until test results are available. If no test results are received after three (3) working days, the employee, if available, shall be returned to work with back pay. If the test results prove negative, the employee shall be reinstated with back pay. In all other cases:
 - a. Applicants testing positive for drug use will not be hired.
 - b. Employees who have not voluntarily come forward, and who test positive for drug use, will be terminated.
 - c. Employees who refuse to cooperate with testing procedures will be terminated.
 - d. Employees found in possession of drugs or drug paraphernalia will be terminated.
 - e. Employees found selling or distributing drugs will be terminated.
 - f. Employees found under the influence of alcohol while on duty, or while operating a company vehicle, will be subject to termination.

3. Prescription Drugs - Employees using a prescribed medication which may impair the performance of job duties, either mental or motor functions, must immediately inform their supervisor of such prescription drug use. For the safety of all Employees, the company will consult with you and your physician to determine if a re-assignment of duties is necessary. The company will attempt to accommodate your needs by making an appropriate re-assignment. However, if a re-assignment is not possible, you will be placed on temporary medical leave until released as fit for duty by the prescribing physician.

4. Grievance - All aspects of this policy and program shall be subject to the grievance procedure of the applicable collective bargaining agreement.

V. DRUG/ALCOHOL TESTING

The parties to this policy and program agree that under certain circumstances, the company will find it necessary to conduct drug and alcohol testing. While "random" testing is not necessary for the proper operation of this policy and program, it may be necessary to require testing under the following conditions:

- A. A new employee shall be eligible to be "pre-employment" tested either prior to starting work or within the first forty-eight (48) hours of employment. The employee is entitled to be compensated for the time required to submit the test;
- B. A test may be administered in the event a supervisor has a reasonable cause to believe that the employee has reported to work under the influence, or is or has been under the influence while on the job; or has violated this drug policy. During the process of establishing reasonable cause for testing, the employee has the right to request his on-site representative to be present;
- C. Testing may be required if an employee is involved in a workplace accident/incident or if there is a workplace injury;
- D. Testing may be required as part of a follow-up to counseling or rehabilitation for substance abuse, for up to a one (1) year period;
- E. Employees may also be tested on a voluntary basis.

Each Employee will be required to sign a consent and chain of custody form, assuring proper documentation and accuracy. If an employee refuses to sign a consent form authorizing the test, ongoing employment by the company will be terminated.

Drug testing will be conducted by an independent accredited laboratory (National Institute on Drug Abuse and/or College of American Pathology), and may consist of either blood or urine tests, or both as required. Blood tests will be utilized for post accident investigation only.

The company will bear the costs of all testing procedures.

VI. REHABILITATION AND EMPLOYEE ASSISTANCE PROGRAM

Employees are encouraged to seek help for a drug or alcohol problem before it deteriorates into a disciplinary matter. If an employee voluntarily notifies supervision that he or she may have a substance abuse problem, the company will assist in locating a suitable employee assistance program for that treatment, and will counsel the employee regarding medical benefits available under the company or union health and welfare/insurance program.

If treatment necessitates time away from work, the company shall provide for the employee an unpaid leave of absence for purposes of participation in an agreed upon treatment program. An employee who successfully completes a rehabilitation program shall be reinstated to his/her former employment status, if work for which he/she is qualified exists.

Employees returning to work after successfully completing the rehabilitation program will be subject to drug tests without prior notice for a period of one year. A positive test will then result in disciplinary action as previously outlined in this policy and program.

**IUOE LOCAL 150
HIRING PROCEDURES**

1. When an employer calls a Referral office for an applicant for employment, they shall be dispatched in a nondiscriminatory manner as follows:

A. Individuals will be furnished in accordance with the provisions of this Agreement and the Regulations governing Referral Offices within forty-eight (48) hours of the time they are requested by the Employer, if they are available, and in the event they cannot be or are not furnished within such period, the Employer may employ any person, but shall arrange for a dispatch order to be obtained for the individual from the appropriate area Referral Office of the Union within twenty-four (24) hours of the commencement of such employment and such dispatch shall upon request be issued to the Employee.

B. When an Employer desires to employ persons not eligible for dispatch to such Employer under the provisions of this Addendum in the performance of work covered by this agreement in the geographical area covered by this Addendum, either by reason of such persons special skills or previous satisfactory employment within the six calendar months next preceding the date of request by the Employer requesting, such Employer shall in writing request the Referral Office servicing the job or project for pre-job conference at least two calendar weeks prior to the commencement of the work or operation of the equipment.

At such pre-job conference the classification and number of such employees and the time of the commencement of their employment or the operational stages of the job or project at which their employment shall commence shall be determined.

Thereafter upon written request of such Employer, signed by an authorized representative of such Employer on a job or project and delivered to the Referral Office servicing such job or project stating that such Employer desires that a named person or persons be referred in a classification or classifications agreed to at such pre-job conference such person or persons shall be referred without regard to the provisions of Addendum No. 1, Sections 4, 5 and 6 of this Agreement and the Employer shall hire such persons or person so referred.

Except as in this Section 1(B), set out, all persons performing work covered by this Agreement within the geographical area covered by this Addendum must be obtained through the appropriate Referral Office of Local Union No. 150.

2. LOCATION OF REFERRAL OFFICES

For the purposes of this Article only the following Referral Offices for referral to Employers for jobs in the area covered by this Agreement shall be recognized.

A. Referral Office No. 1 located at 6200 Joliet Road, Countryside, Illinois, and embracing the Counties of Cook and DuPage.

B. Referral Office No. 2 located Joliet, Illinois, and covering Counties of Kane, Kendall, Grundy, Will and Kankakee.

C. Referral Office No. 3 located at Waukegan, Illinois covering the Counties of Lake and McHenry.

D. Referral Office No. 4 located at Rockford, Illinois covering Counties of Winnebago, Boone, Stephenson, Carroll, Joe Daviess, Lee, Whiteside, DeKalb and Ogle.

E. Referral Office No. 5 located at Ottawa, Illinois and covering the Counties of LaSalle, Livingston, the Eastern one-half (1/2) of Bureau and the Eastern one-half (1/2) of Putnam County.

F. Referral Office No. 6 located at South Bend, Indiana, covering the Counties of Elkhart, LaGrange, Marshall, St. Joseph, Fulton, Kosciusko and Noble.

G. Referral Office No. 7 located at Merrillville, Indiana, and covering the Counties of Lake, Newton, LaPorte, Porter, Jasper, Starke and Pulaski.

3. REFERRAL LISTS

Each Referral Office shall maintain the following lists on which person not currently employed in the highway, general building and heavy construction or related industry may register for Referral at any time during which the Referral Office is open:

A. List 1, persons seeking active employment, i.e., each Operating Engineer who has been employed or available for employment, in the area embraced by the Referral Office in which the person seeking active employment is registering for Referral, for a period of four (4) years, i.e., forty-eight (48) months next preceding his registering for Referral in any one or more classifications set out in the Wage Classification of this Agreement on the type or kind of craft work of Operating Engineers.

B. List 2, persons seeking active employment, i.e., each Operating Engineer who has been employed or available for employment in the area embraced by all Referral Offices for a period of four (4) years, i.e., forty-eight (48) months next preceding his registering for Referral, in any one or more classifications set out in the Wage Classification of this Agreement, on the type or kind of craft work of Operating Engineers.

"Preferred" registration of Lists 1 and 2 shall be permitted with regard to the following classifications: AIR COMPRESSORS, TUGGER HOISTS, HEATERS, ROLLERS, WELDING MACHINES, CONVEYERS, GENERATORS AND ELEVATOR HOISTS.

EXCEPT WHEN A DUAL PURPOSE OPERATOR IS REQUIRED.

A person making a "preferred" registration shall:

(1) Be ineligible to register and shall not register for work in any classification which is not "preferred".

(2) Be 60 or more years of age and have had at least ten (10) years of employment, or available employment, in any one or more classifications contained in this Agreement, in the area defined in this Article, provided, however, that a person who does not meet such requirements but who has a physical handicap preventing his employment in any classification except one which is "preferred" and is a List 1, 2, 3, or 4 person, or acquired such handicap as a result of an industrial accident while employed as Operating Engineer, shall be permitted to so register.

(3) All persons making a "preferred" registration shall designate at the time of such registration the specific "preferred" classifications set forth above on which such person is both qualified and physically able to be employed. No persons making a "preferred" registration may simultaneously be registered for employment in non-"preferred" classifications. All persons who are registered in a "preferred" classification may change to a non-"preferred" classification when they no longer have a physical handicap preventing such registration, as evidenced by a written medical opinion. All persons making such a change of registration shall maintain their date of registration as if no change had been made.

C. List 3, person seeking active employment, i.e., each Operating Engineer who has been employed or available for employment, in the area embraced by the Referral Office in which the person seeking active employment is registering for Referral, for a period of less than four (4) years, i.e., forty-eight (48) months but not less than one (1) year, i.e., twelve (12) months next preceding his registering for Referral, in any one or more classifications set out in the Wage Classification of this Agreement, on the type or kind of craft work of Operating Engineers.

D. List 4, persons seeking active employment, i.e., each Operating Engineer who has been employed or available for employment in the area embraced by all Referral Offices for a period of less than four (4) years, i.e., forty-eight (48) months but not less than one (1) year next preceding his registering for Referral, in any one or more classifications set out in the Wage Classification of this Agreement, on the type of kind of craft work Operating Engineers.

E. List 5, persons seeking active employment, i.e., each Operating Engineers who has been employed or available for employment in the area embraced by all Referral Offices within a period of not more than (1) year, i.e., twelve (12) months next preceding his registering for Referral, in any one or more classifications set out in the Wage Classification of this Agreement on the type or kind of craft work of Operating Engineers, or a person seeking active employment who has not been employed in the area embraced by all Referral Offices and can meet none of the tests set out in sub-paragraphs A through D last above set out.

F. Separate lists shall be kept for Apprentices on the same basis as for Operating Engineers. The Apprentices' preference is limited to Apprentices, and Operating Engineers' preference is limited to Operating Engineers, provided that an Apprentice with a preference shall, upon being dispatched as an Operating Engineer and being employed as an Operating Engineer, thereafter have the same preference as he had as an Apprentice. For the purposes of this Addendum No. 1 only the term "Apprentice" shall include the following classifications: HELPERS, OILERS, TRUCK CRANE OILERS AND INSTALLING WELLPOINTS.

The foregoing lists shall be maintained on the basis of the written statement of the person seeking active employment.

G. An employee who while employed or a person registered for Referral:

- (1) becomes incapacitated by reason of any injury or disease arising out of and in the course of employment on the type or kind of craft work of Operating Engineers shall for all purposes of this Addendum No. 1 be considered employed or available for employment for the full period of incapacity, or
- (2) becomes incapacitated by reason of any injury or disease not arising out of and in the course of employment on the type or kind of craft work of Operating Engineers shall for all purposes of this Addendum No. 1 be considered employed or available for employment if a Class 1 or 2 person seeking active employment for the period of incapacity, but in no event for more than four (4) years, and if a Class 3 or 4 person seeking active employment for the period of incapacity, but in no event for more than three (3) years.

H. No person seeking active employment may register for Referral as an Operating Engineer and an Apprentice at the same time.

I. Any person, who, while registered for Referral in a Referral Office, accepts employment in the highway, general building and heavy construction or related industry other than under this Addendum shall notify the Referral Offices in which he is registered in writing within forty-eight (48) hours after such acceptance to strike his name from the list or lists on which he registered. Upon complaint being filed by a Referral Office with the Board created under the Joint Arbitration Clause of this Addendum that any such person has failed to give the notice required by the Sub-Paragraph, and if such person had been given notice of such complaint and opportunity to be heard, the Board may deny such person the right to register for Referral for a period to be fixed by such Board but which shall not exceed one (1) year.

J. All persons seeking active employment when registering shall set forth their name, address and telephone number and classification or classifications of work sought and their experience therein and may change such classification or classifications at any time before being dispatched.

4. ORDER OF DISPATCH

In dispatching, each Referral Office shall dispatch those on List 1 so long as there are any in the classification requested by the Employer who are registered and available for work and thereafter those on List 2 so long as there are any in the classification requested by the Employer who are registered and available for work and thereafter those List 3 so long as there are any in the classification requested by

the Employer who are registered and available for work and thereafter to those on List 4 so long as there are any in the classification requested by the Employer who are registered and available for work.

In the event the request is for employment for five (5) or more working days in the event that there is no registrant in the classification called for on Lists 1 through 4 or there is no registrant available for work on Lists 1 through 4, the Referral office of which the request is originally made shall contact the Referral Office nearest the job or project, which office shall proceed as in the paragraph last above set out. In the event such Referral Office has no registrant available for work, the Referral Office of which the request is originally made shall contact the remaining Referral Offices, which offices shall proceed as in the paragraph last above set out. Any person dispatched under this paragraph shall be considered as working in the area embracing the Referral Office which issued the dispatch for the duration of his employment.

In the event, after proceeding as set out above, no Referral Office is able to fill the request, such Referral Office of which the request was originally made shall dispatch those on List 5 so long as there are any in the classification called for by the Employer who are registered and available for work.

5. LIST PLACEMENT

Subject to Sections 8 A through D of this Addendum No. 1, all registrants on Lists 1 through 4 shall be dispatched in the order of registrant's date of registration as available for work and in accordance with their experience as Operating Engineers in the Construction Industry, i.e., the earliest registered individual with the required experience first, as established by the written statement of the registrant, required by Section 3(J) above, and thereafter in order of date of registration. A registrant shall have the right to submit any dispute to the joint Arbitration Board established by the Arbitration Clause in this contract in accordance with paragraph 13 of this Addendum. The name of a registrant so dispatched shall be stricken from the list when dispatched. However, a dispatched registrant shall resume the former position on the applicable registration list upon the Referral Office's notification that the registrant is again available for work and actually worked for the last employer ten working days or less.

6. CALL BACK - LIST 5

All persons on List 5 shall be dispatched in order of registrant's date of registration as available for work and in accordance with their experience as Operating Engineers as established by the written statement of the registrant required by Section 3(J) above. When dispatched their names shall be stricken from the list, provided, however, that upon written request of a signatory employer, signed by the senior representative of the employer on a job or project and delivered to the Referral Office embracing such job project stating that the employer desires, on the basis of past satisfactory service, that a named Class 5 registrant be dispatched to such job or project, such Referral Office shall dispatch such Class 5 registrant only after the following conditions have been met.

- A.** No employee shall be laid off or discharged to make room for such person.
- B.** The requested registrant must have been in the employ of the requesting Employer for a period of eighteen (18) months or more from the date of the signing of this Agreement.
- C.** The Employer shall not request more than one (1) Class 5 registrant by name in each calendar year.
- D.** The Employer shall not request a Class 5 registrant by name in the months of December, January, February or March.
- E.** The Employer shall not request a Class 5 Registrant unless he has in his employ six (6) or more persons classified as Operating Engineers working in the area covered by this Agreement.

7. CANCELLATION OF REGISTRATION

Registration on Lists 1 through 4 shall be valid until cancelled or registrant is dispatched.

Registration on List 5 shall be valid for one (1) calendar month only, and no such registration shall be carried over to the succeeding month. Any person not dispatched during the calendar month in which he registers shall, if he desires, be available for dispatch upon re-registration.

Any registrant of the Referral Office of which a request is originally made who refuses three consecutive dispatches for any reason shall have his name placed at the end of the list on which he is registered.

8. CALL BACK - LIST 1 THROUGH 4

Regardless of anything in these Regulations to the contrary:

A. Upon written request of an Employer, signed by the senior representative of the Employer on a job or project and delivered to the Referral Office embracing such job or project stating that such Employer desires, on the basis of past satisfactory service within the preceding thirty-six (36) calendar months, that a named Class 1, Class 2, Class 3, or Class 4 registrant be dispatched in particular classification to such job or project, such Referral Office shall dispatch such registrant in such classification to such job or project, provided such person is registered in such Referral Office and available for work at the time of the receipt of the written request and has also been so registered with the Referral Office for at least seven (7) days if the person had quit previous employment voluntarily and provided, further, that no employee shall be laid off or discharged except for cause to make room for such person.

In the event the named person is not registered or not available for work at the time of the receipt of a written request under this Section 8(A), the Referral Office shall so notify the employer as soon as possible, and the forty-eight (48) hour period provided in Section 1 shall not commence to run until receipt by the Referral Office of either a request for an unnamed registrant by classification or a further request under this Section 8(A) for a named person who is registered and available for work at the time of the receipt of the written request or a request under Section 8(B).

For all purposes of this Section 8(A) employment by an employer engaged in a joint venture on work for which one or more employer parties to such joint venture is responsible to such joint venture shall be considered employment of a registrant only by the one employer to whom the registrant was dispatched.

B. Upon written request of an Employer, signed by the senior representative of the Employer on a project and delivered to the Referral Office embracing such job or project stating that such Employer desires an Employee in a particular classification who has had either (i) a specified number of months or years (not to exceed, however, twenty-four (24) months or two (2) years) experience on a particular type of equipment or (ii) a specified number of months or years (not to exceed, however, twenty-four (24) months or two (2) years) experience on a particular type of work, or both, the Referral Office shall contact, if available, the persons in that classification registered and available, for work in the order in which they would be dispatched under paragraphs 4 and 5 of these Regulations and inquire of the registrant as to his experience under (i) and (ii) and the Referral Office shall dispatch the first such registrant who advises the Referral Office that he has such experience.

In the event no person with the requisite experience is available the Employer ordering such person shall not be free to hire directly a person to operate such piece of equipment or perform such work who has had less experience than the experience called for in the order.

C. In the case of two or more pieces of new equipment (that is, types of equipment developed to which present classifications and working rules are not fairly applicable) not previously used in the area covered by this agreement, the number of months experience on such new equipment which may be specified in the request shall be six (6) months less than the number of months the two or more pieces of new equipment have been used in the area covered by this Agreement.

D. When an individual Employer rents or leases equipment, a List 1 or 2 Employee of the lessor operating of the equipment may be transferred to the payroll of the lessee, but shall be considered an Employee of the lessor for the purposes of these nondiscriminatory hiring procedures, provided such Employee has been dispatched in accordance with these nondiscriminatory hiring procedures and shall have been in the employ of the lessor, or a lessee of the lessor, for the five (5) working days next preceding the date of the rental of the equipment, and the Referral Office servicing the job or project on

which such equipment is to be used is notified in writing by the Lessee, before twelve o'clock noon of the day prior to the first day such equipment is to be used on the job or project, and provided further that such Employee's employment by the lessee shall terminate upon the termination of the lease or rental of the equipment or replacement.

9. EMPLOYER RESPONSIBILITY

The Employer may reject any registrant dispatched by a Referral Office for employment. The Employer shall determine the registrants' ability and competence to satisfactorily perform the work prior to on the job employment. Such determination shall not be the responsibility of the Union.

10. PRO RATA COST SHARING

The cost and expenses of maintaining the referral system shall be borne by all applicants for employment. In the case of applicants who are not members of the Union, their share of such cost and expenses shall not exceed a sum equal to the pro rata share of the costs and expenses of operating the referral system and the referral therefrom which is being borne by the members of the Union from the payment of dues. Upon the date of registration or dispatch at the referral office, the applicant shall incur the obligation of making payments of their pro rata share of such cost and expenses.

11. NON-DISCRIMINATION

The Union and the Employer and each Referral Office of the Union, in carrying out the provisions of this Agreement with respect to HIRING and the registration and dispatch of persons seeking active employment, will not discriminate either in favor of or against such registrants, or persons seeking to register by reason of membership in or non-membership in any Union, nor shall the carrying out of the provisions of this Agreement with respect to HIRING and the registration and dispatch of persons seeking active employment be based on, or in any way affected by Union membership, bylaws, rules, regulations, constitutional provisions or any other aspect or obligation of Union membership, policies or requirements. The Employer shall not discriminate either in favor of or against persons seeking active employment or any of them by reason of membership or non-membership in any Union or by reason of acting on behalf of or in opposition to any Union.

12. REPORTING FOR WORK

Upon being dispatched, the registrant shall proceed to the job at once. When call is made to a Referral Office for persons to report to work on day of request a reasonable time shall be allowed for persons traveling to the job site as agreed by the Referral Office. A registrant who fails to report for work when dispatched on the shift to which dispatched or within the time agreed to if dispatched to work on the day of request without good cause therefore shall not be eligible for dispatch for seven (7) days thereafter. When a registrant is requested by Employer to be dispatched on the day of request, and the registrant dispatched does report for work that same day, he shall be paid for his full shift.

13. JOINT ARBITRATION BOARD

Any Employee or applicant for employment aggrieved by the operation of the registration facilities or Referral Offices of the Union, or these Regulations as applied to that person has the right to submit their grievance to the Joint Arbitration Board created by the Joint Arbitration Clause of this Agreement provided that such submission is made in writing within ten (10) days after the occurrence of the grievance. The Board shall have the full power to adjust the grievance and its decision thereon shall be final and binding upon the Employee or applicant for employment and upon all other parties thereto.

Forms for the submission of such grievance shall be available at all times in each Referral Office.

14. WORK IN OTHER AREAS

A. An Employee who while employed on the type or kind of craft work of Operating Engineers, or who was or is transferred by an individual Employer to a job or project outside of the area covered by this Agreement, and was or is there employed by such individual Employer or by a Joint Venture with which said individual Employer is associated on the type or kind of craft work covered by this Agreement, shall for all purposes of this Addendum No. 1, be considered to have been employed or registered for employment in the area covered by this Agreement for the period of such services outside of the area covered by this Agreement.

15. MILITARY OR OTHER SERVICE

An Employee who since August 15, 1960, while employed or registered for employment or prior to August 16, 1960 was employed or available for employment in any one or more classifications set out in the Wage Classification of This Agreement on the type or kind of craft work of Operating Engineers, entered or enters the Military Service of the United States or Works for Local Union No. 150 or its International Union as an Employee or elected officer shall for all purposes of this Addendum be considered employed or registered for employment in the geographical area covered by this Addendum for the period of such Military Service or work for the Local Union or its International Union.

16. EMPLOYER INDEMNIFICATION

It is expressly understood and agreed between the Employer and the Local Union that any registrant dispatched by a Referral Office and put to work shall be regarded for the purposes of this agreement as an employee of the Employer, and the Employer shall and hereby does indemnify and save harmless and the said Local Union from any and all liability on account of injury or death of third persons or injury or destruction of the property of third persons where such injury or death to persons or injury or destruction or property shall be caused by the negligence or willful and wanton acts of said employee in the course of his employment. The Employer further shall and hereby does indemnify and save harmless the Local Union from all claims and demands, suits, actions, loss, damages, recoveries, judgments costs or expenses in any manner arising out of or in connection with any such injury, death, loss or damage.

17. It is expressly understood and agreed between the employer and the Union that all referrals to employers shall be made on a non-discriminatory basis. The Union shall and hereby does agree to defend, indemnify and hold harmless the said employer from any and all liability on account of the alleged discriminatory operation of the referral offices and/or the alleged unlawful administration of the referral process prior to the employer's consideration of applicants. The Union further shall defend, indemnify and hold harmless the employer from all claims and demands, suits, actions, administrative proceedings, recoveries, judgment, costs and expenses or other liabilities in any manner arising out of or in connection with any alleged discriminatory referral office operation or administration as specified herein.

18. POSTING

These regulations shall be posted on the Bulletin Board in each Union Referral Office and the Bulletin Boards of the Employers where notices to Employees and applicants for employment are posted.